

KAC-PS621 KAC-X621

SERVICE MANUAL

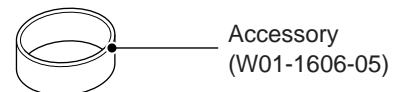

BLOCK DIAGRAM

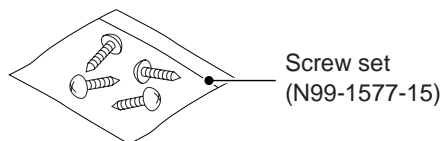
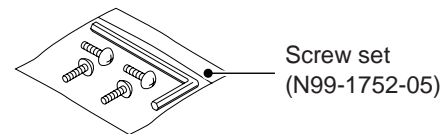
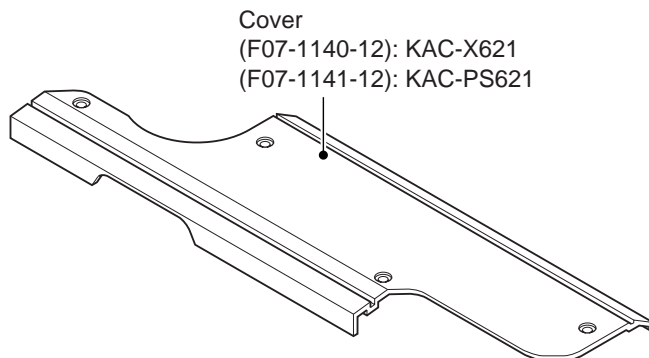
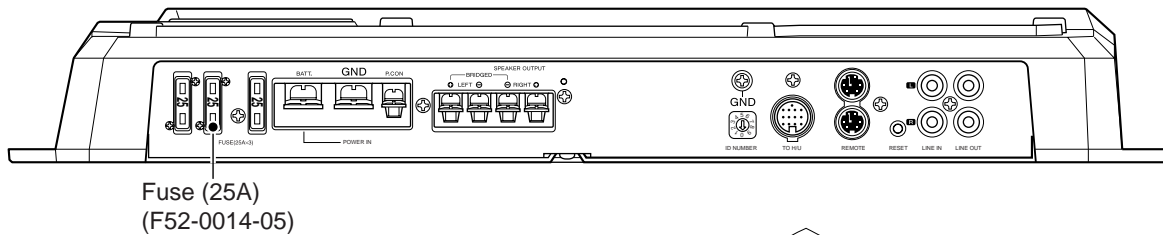
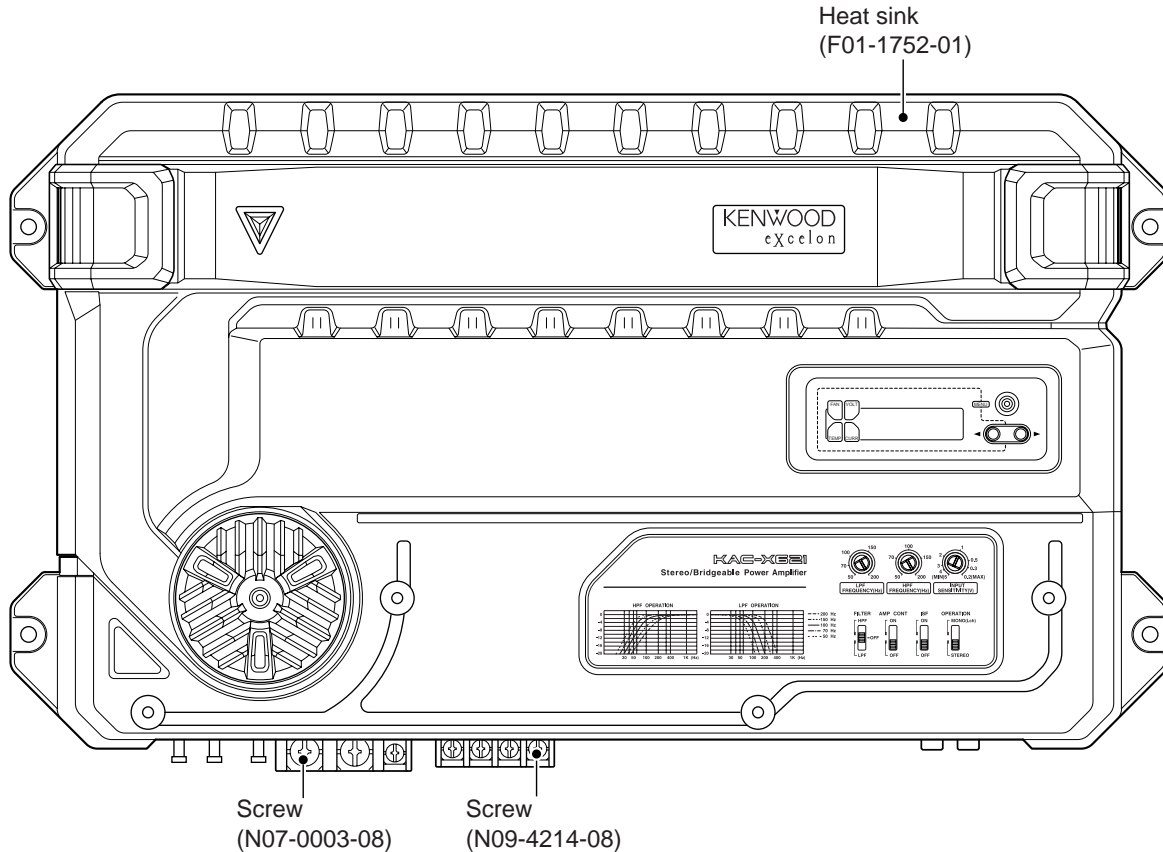
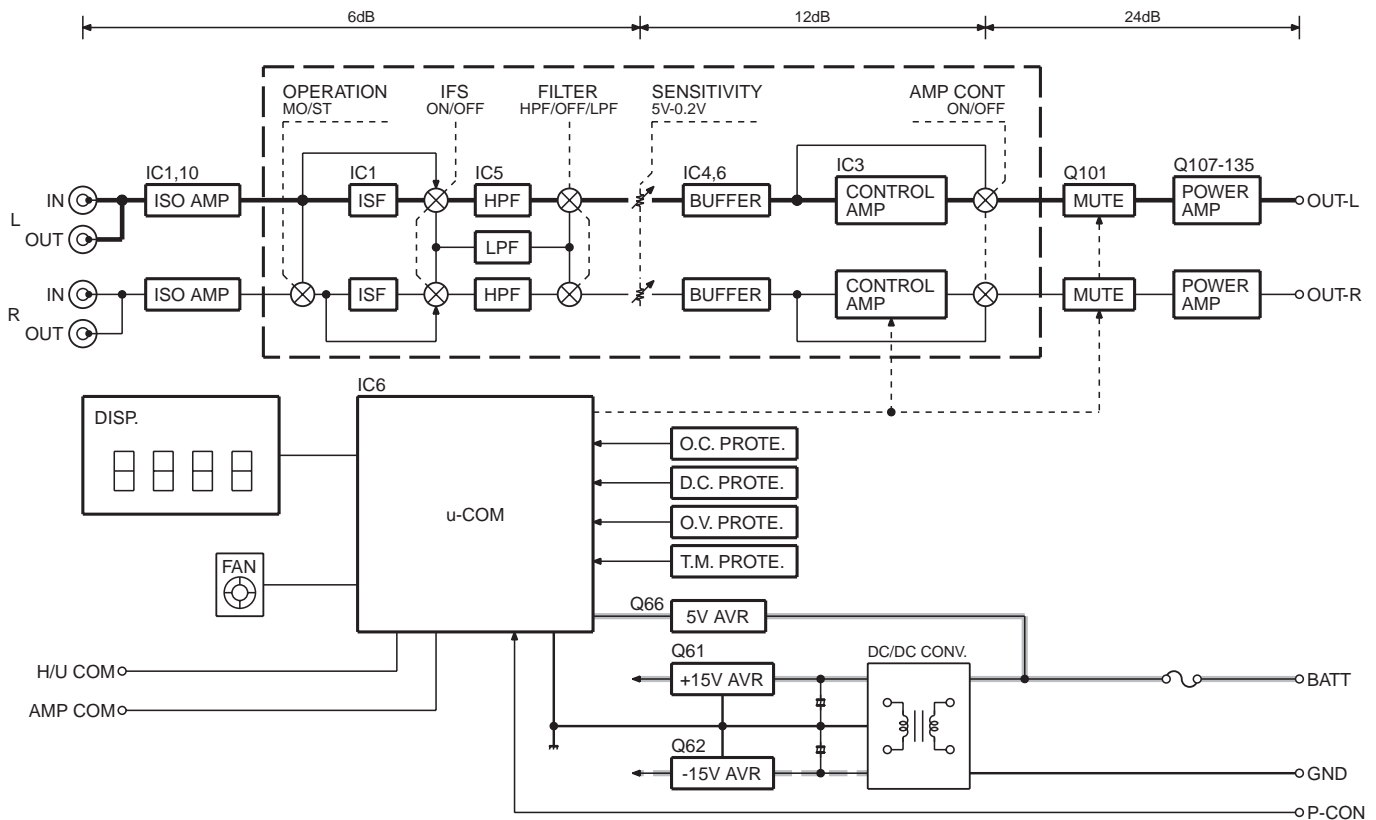

COMPONENTS DESCRIPTION

● PREAMPLIFIER UNIT (X08-4150-10)

Ref. No	Application / Function	Operation / Condition / Compatibility
IC1	Infrasonic filter	
IC3	Tone and volume variable	Controlled by microprocessor
IC4	6dB voltage amplification	
IC5	HPF	
	LPF	
IC6	Lch : 6dB voltage amplification	
	Rch : Signal 180 reverse and 6dB voltage amplification	
IC7	LCD driver	Controlled by microprocessor

● AUDIO UNIT (X09-5770-10)

Ref. No	Application / Function	Operation / Condition / Compatibility
IC1	Buffer	
IC2	DC/DC converter	
IC3	AMP communication buffer	

COMPONENTS DESCRIPTION

Ref. No	Application / Function	Operation / Condition / Compatibility
IC5	H/U communication buffer	
IC6	Microprocessor	
IC7	Reset IC	
IC9	Current detection	
IC10	Isolation amplifier	
Q50	5V AVR	
Q51~54	DC/DC output driver	
Q55~60	DC/DC drive (Final)	
Q61	+15V AVR	
Q62,63	-15V AVR	
Q64,65	DC/DC converter (IC2) ON/OFF	Controlled by microprocessor
Q66,68	5V AVR	
Q69	5V AVR ON/OFF	
Q70,71	P-CON control	
Q81	+15V AVR (Constant current)	
Q91,92	DC/DC control	
Q97	AMP communication stability power supply	
Q101,102	Mute	
Q103~112	A class first stage amplifier	
Q113~118	A class 2nd stage amplifier	
Q119,120	Final temperature compensation	
Q121~124	Amplifier current detection (Current limiter)	
Q125~132	Final driver	
Q133~140	Final	
Q141	Mute control	
Q142~145	Shock noise prevention	
Q146,147	AMP current detection	
Q148,149	DC detection	
Q249,250,263	ATT control	Synchronized with temperature detection
Q301~307	H/U communication output driver	
Q310	H/U communication ON/OFF	
Q313	H/U communication output driver	
Q341~344	H/U communication input driver	
Q346	H/U communication output driver	
Q347~349	AMP and H/U communication ON/OFF control	
Q351,352	BATT voltage output	
Q353~358	Fan stability power supply	
Q403	LCD backlight LED control	
Q404	LED control	
Q601,602	DC/DC drive (Final)	

KAC-PS621/X621

MICROCOMPUTER'S TERMINAL DESCRIPTION

● MICROPROCESSOR : 784224YGC117 (X09 : IC6)

◇ Block Diagram

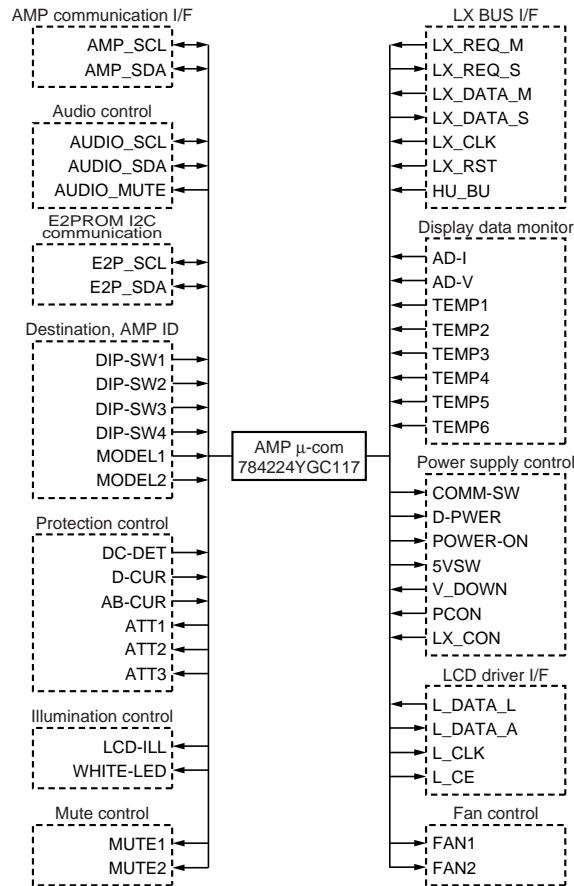

◇ Terminal Function

Pin No.	Pin Name	I/O	Function	Processing Operation Description
1~3	TEMP4~TEMP6	I	Temperature detection 4~6	
4	AVSS	-	GND	
5	L_CE	O	CE output to LCD driver	H : LCD driver CE
6	LX_REQ_S	O	Data transmit request to H/U	H : OFF, L : ON
7	AVREF1	-	DA reference voltage	
8	L_DATA_L	I	Data input from LCD driver	
9	L_DATA_A	O	Data output to LCD driver	
10	L_CLK	O	CLK output to LCD driver	
11	LX_DATA_M	I	Data input from H/U	
12	LX_DATA_S	O	Data output to H/U	
13	LX_CLK	I	CLK input from H/U	
14	LX_BU	I	LX BUS communication, H/U connect detection	H : Not connect (Except master amplifier), L : Connect
15	NC	O	Not used	
16	SDA_AMP	I/O	Data input/output AMP communication	
17	NC	O	Not used	

MICROCOMPUTER'S TERMINAL DESCRIPTION

Pin No.	Pin Name	I/O	Function	Processing Operation Description
18	SCL_AMP	I/O	CLK input/output AMP communication	
19	AUDIO_SCL	I/O	CLK input/output with audio chip	
20	AUDIO_SDA	I/O	Data input/output with audio chip	
21	AUDIO_MUTE	O	Mute output to audio chip	H : Mute OFF, L : Mute ON
22	E2P_SCL	I/O	CLK input/output with E2PROM	
23	E2P_SDA	I/O	Data input/output with E2PROM	
24	NC	O	Not used	
25~28	DIP-SW1-DIP-SW4	I	AMP address setting	
29	MODEL1	I	Model setting 1	
30	MODEL2	I	Model setting 2	
31,32	NC	O	Not used	
33	VSS1	-	GND	
34~37	NC	O	Not used	
38	LCD-ILL	O	LCD backlight switch	H : ON, L : OFF
39	WHITE-LED	O	Triangle illumination switch	H : ON, L : OFF
40	NC	O	Not used	
41~43	ATT1~ATT3	O	Output attenuate due to rise in temperature 1~3	H : Attenuate, L : Not attenuate
44,45	NC	O	Not used	
46	COMM-SW	O	Communication IC power switch	H : ON, L : OFF
47~50	NC	O	Not used	
51	D-PWER	O	D class amplifier power supply control	H : ON, L : OFF (2ch/4ch L fixed)
52	DC-DET	I	Speaker output DC voltage detection	H : Normal, L : Abnormal
53	NC	O	Not used	
54	POWER-ON	O	Amplifier power supply control	H : ON (D/AB class), L : OFF
55	5VSW	O	5VSW	H : OFF, L : ON
56	MUTE1	O	Amplifier section input stage mute control	H : OFF, L : ON
57	MUTE2	O	Driver stage pop-noise mute control	H : OFF, L : ON
58	FAN1	O	Fan rotation control	H : Operate, L : Stop
59	FAN2	O	Fan speed control	H : Low speed, L : High speed
60	RESET	-	Hard reset	H : Normal, L : Reset
61	PCON	I	Amplifier power control	H : OFF, L : ON
62	LX_CON	I	LX-BUS communication control	H : OFF, L : ON
63	LX_REQ_M	I	Data receive request from H/U	H : ON, L : OFF
64	NC	O	Not used	
65	V_DOWN	I	Momentary power down detection	H : ON (Power down detection), L : OFF (L fixed)
66	NC	O	Not used	
67	VSS0	-	GND	
68	VD1	-	VDD	
69	X2	-	Main clock input 1	
70	X1	-	Main clock input 2	

KAC-PS621/X621

MICROCOMPUTER'S TERMINAL DESCRIPTION

Pin No.	Pin Name	I/O	Function	Processing Operation Description
71	TEST	-	Flash ROM writing	
72	XT2	-	Not used	
73	XT1	-	Not used	
74	VDD0	-	VDD	
75	AVDD	-	VDD	
76	AD-I	I	First current detection (for display)	
77	AD-V	I	BU voltage detection (for display)	
78~80	TEMP1~TEMP3	I	Temperature detection 1~3	

◇ Logic Table

1) Destination

The destination in AMP does not mean the sales regions but specific models.

The following are the models. When reset is released, it is checked only once.

Model name	MODEL1 (29pin)	MODEL2 (30pin)
KAC-PS811D/X811D	Low	Low
KAC-PS521/X521	Low	High
KAC-PS621/X621	High	Low
KAC-PS541/X541	High	High

2) AMP ID

AMP ID is checked only once at the time reset is released or when the microcomputer is released from the low consumption mode.

When set to AMP ID 8/9 no remote control is possible.

AMP ID	DIP-SW1 (25pin)	DIP-SW2 (26pin)	DIP-SW3 (27pin)	DIP-SW4 (28pin)
0	High	High	High	High
1	Low	High	High	High
2	High	Low	High	High
3	Low	Low	High	High
4	High	High	Low	High
5	Low	High	Low	High
6	High	Low	Low	High
7	Low	Low	Low	High
8	High	High	High	Low
9	Low	High	High	Low

3) Fan speed

Operation	FAN1 (58pin)	FAN2 (59pin)
Stop	Low	High/Low
Low speed	High	High
High speed	High	Low

CIRCUIT DESCRIPTION

● Current detection circuit

Amplify and rectify potential differences at two points in the primary-side current circuit and send it to the AD-port of the MPU and obtain data for displaying current value.

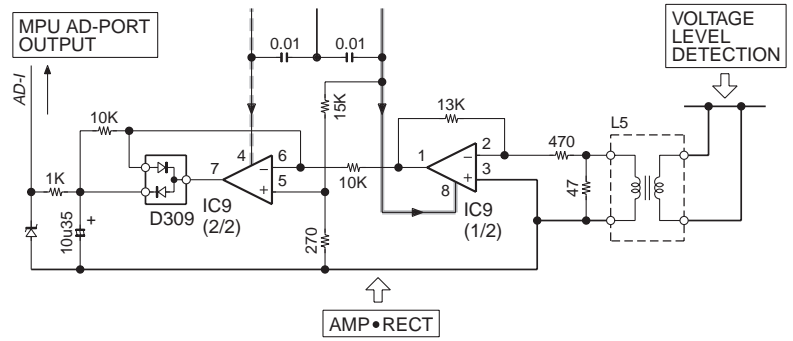

● Constant current output circuit

Remove troubles caused by the potential differences between the constant current output and the GND, so that the GND potential differences between the H/U and the AMP is not overlapped in the AMP to H/U communication.

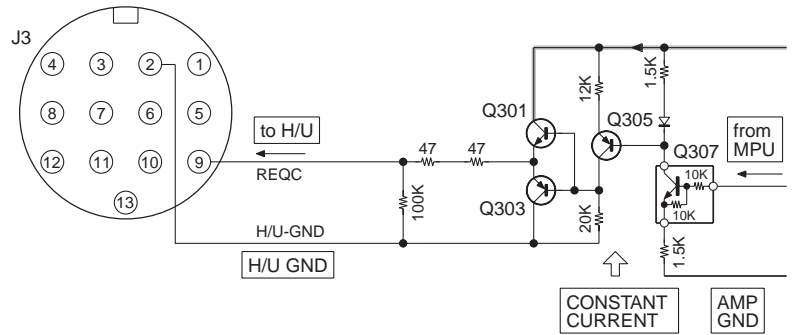

● I2C buffer

Using an IC for I2C communication, between-AMP communication is conducted so that there will be no trouble from GND potential differences.

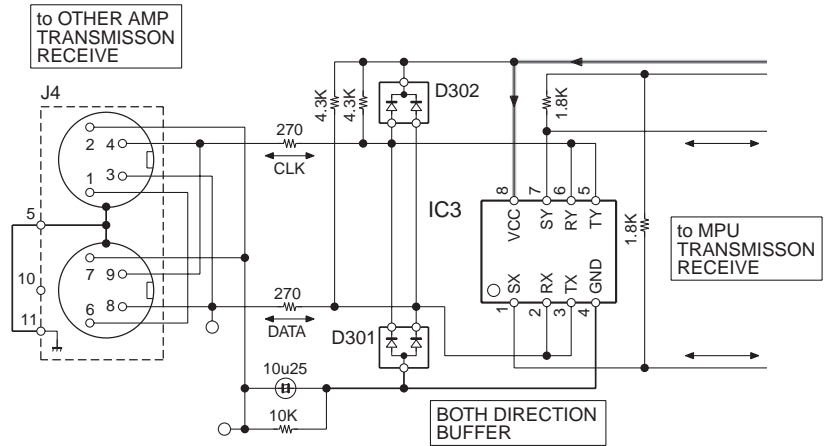

ADJUSTMENT

No.	Item	Alignment Point	Method	Align For	Note	Fig.
1	IDEL CURRENT	VR1 (Lch) VR2 (Rch)	Connect a DC voltmeter between check land A, B.	2.5mV	After Power on 2 minutes	PC board (X09-577)

KAC-PS621/X621 PC BOARD (COMPONENT SIDE VIEW)

PREAMPLIFIER UNIT X08-4150-10 (J76-0010-12)

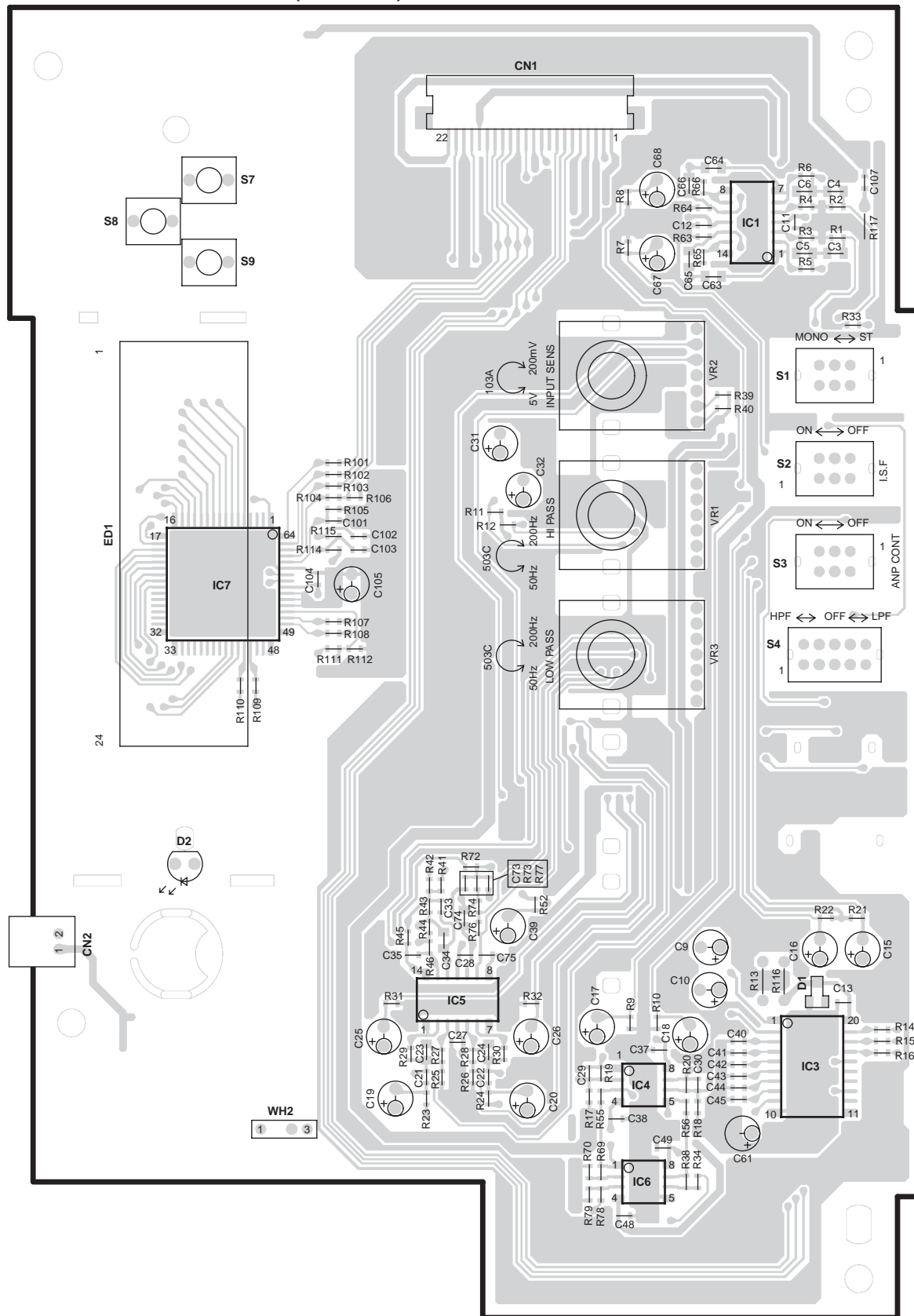

X08-4150-10

Ref. No.	Address
IC1	2D
IC3	6D
IC4	6D
IC5	6C
IC6	6D
IC7	4B

Refer to the schematic diagram for the values of resistors and capacitors.

PC BOARD (FOIL SIDE VIEW)

PEAMPLIFIER UNIT X08-4150-10 (J76-0010-12)

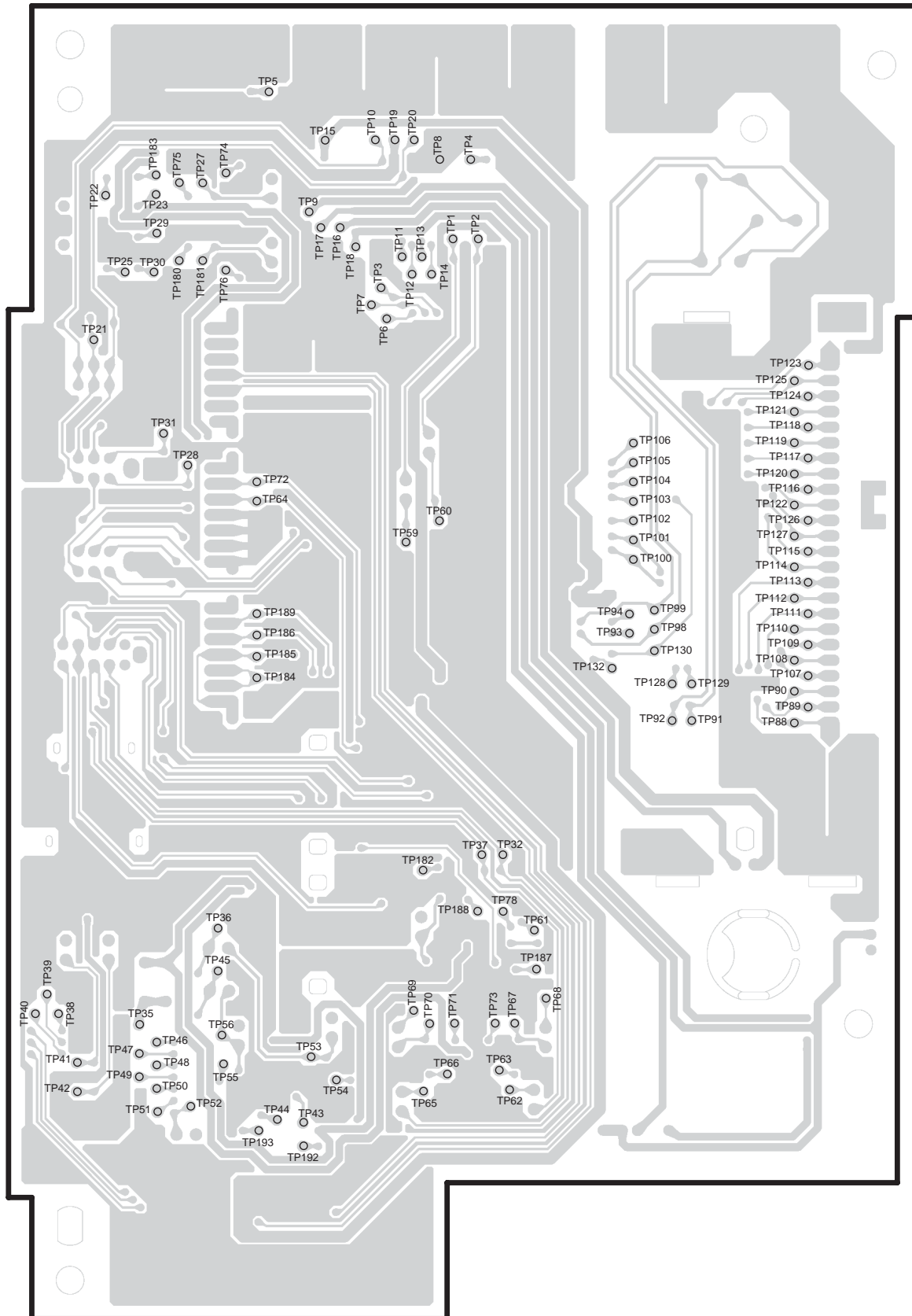

Refer to the schematic diagram for the values of resistors and capacitors.

KAC-PS621/X621 PC BOARD (FOIL SIDE VIEW)

AUDIO UNIT X09-5770-10 A/2 (J76-0007-01)

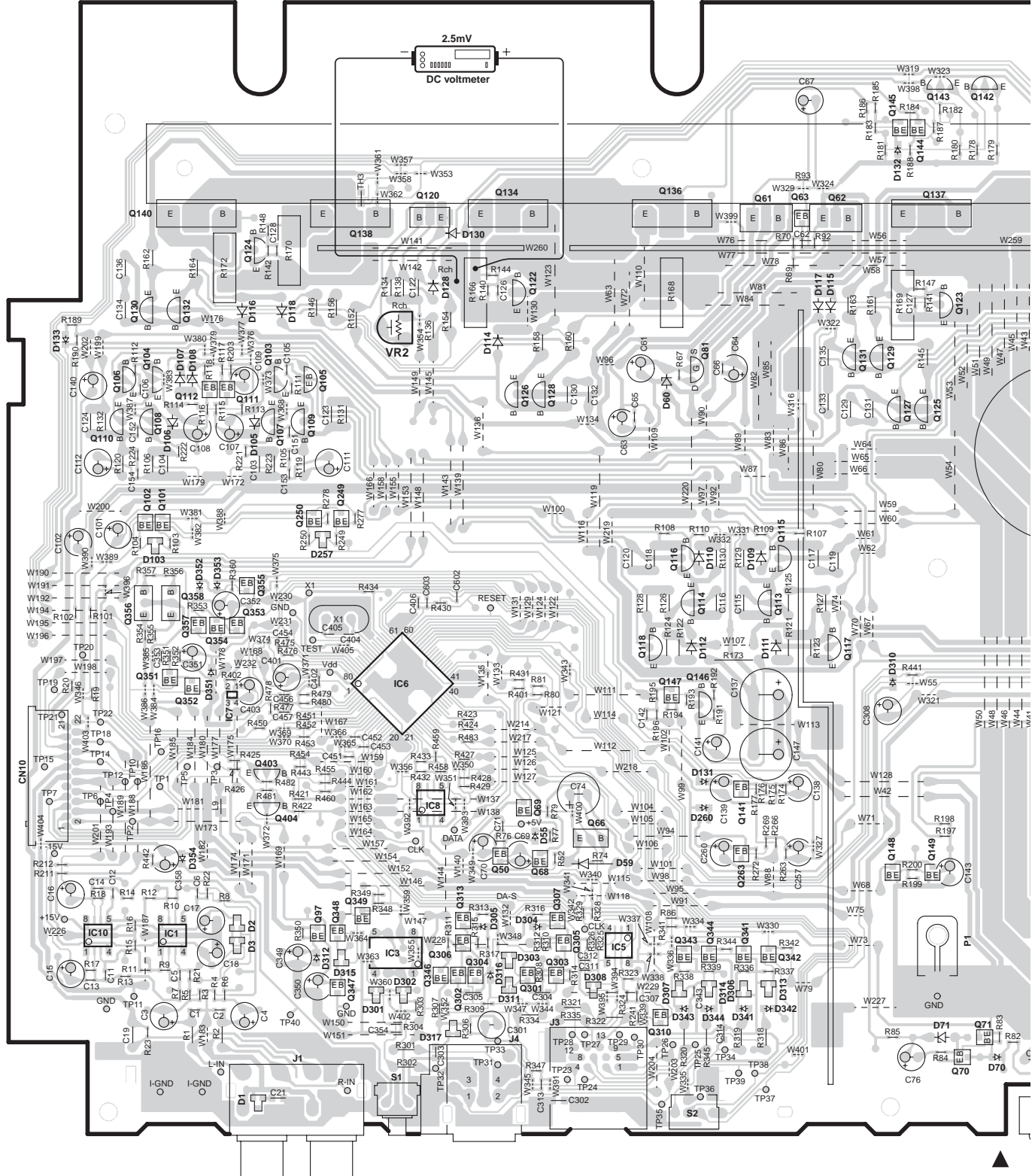

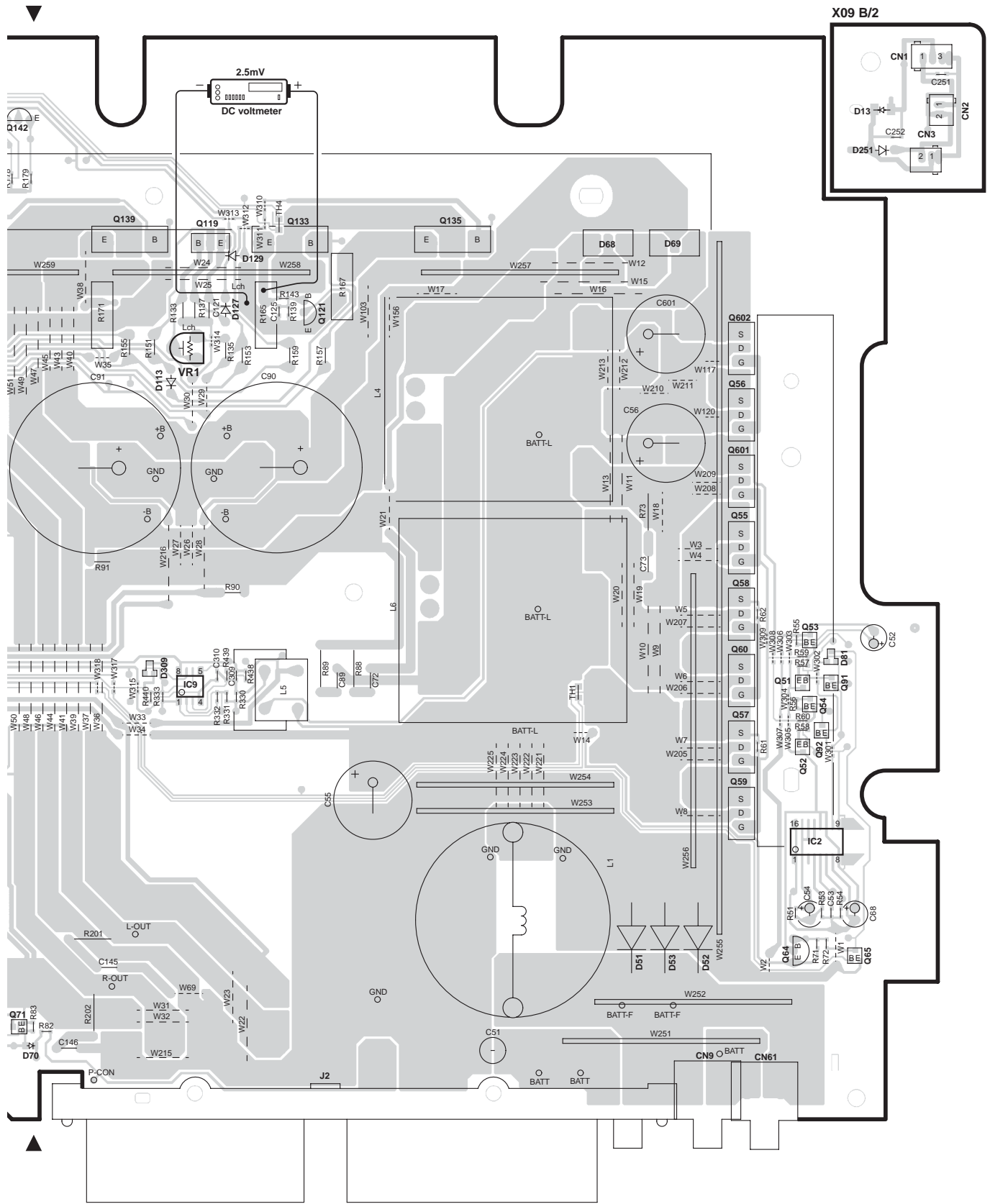

Ref. No.	Address	Ref. No.	Address	Ref. No.	Address	Ref. No.	Address	Ref. No.	Address	Ref. No.	Address	Ref. No.	Address	Ref. No.	Address
Q128	3M	Q134	2M	Q140	2K	Q146	4N	Q263	5N	Q306	5M	Q343	5N	Q351	4L
Q129	3O	Q135	2R	Q141	5N	Q147	4N	Q301	6M	Q307	5M	Q344	5N	Q352	4L
Q130	3K	Q136	2N	Q142	2O	Q148	5O	Q302	6M	Q310	6M	Q346	5M	Q353	4L
Q131	3O	Q137	2O	Q143	2O	Q149	5O	Q303	5M	Q313	5N	Q347	6L	Q354	4L
Q132	3L	Q138	2L	Q144	2O	Q249	3L	Q304	5M	Q341	5N	Q348	5L	Q355	4L
Q133	2Q	Q139	2P	Q145	2O	Q250	3L	Q305	5M	Q342	5N	Q349	5L	Q356	4K
														Q357	4L
														Q358	4L
														Q403	5L
														Q404	5L
														Q601	3S
														Q602	2S

Refer to the schematic diagram for the values of resistors and capacitors.

KAC-PS621/X621

(X09-5770-10) (A/2)

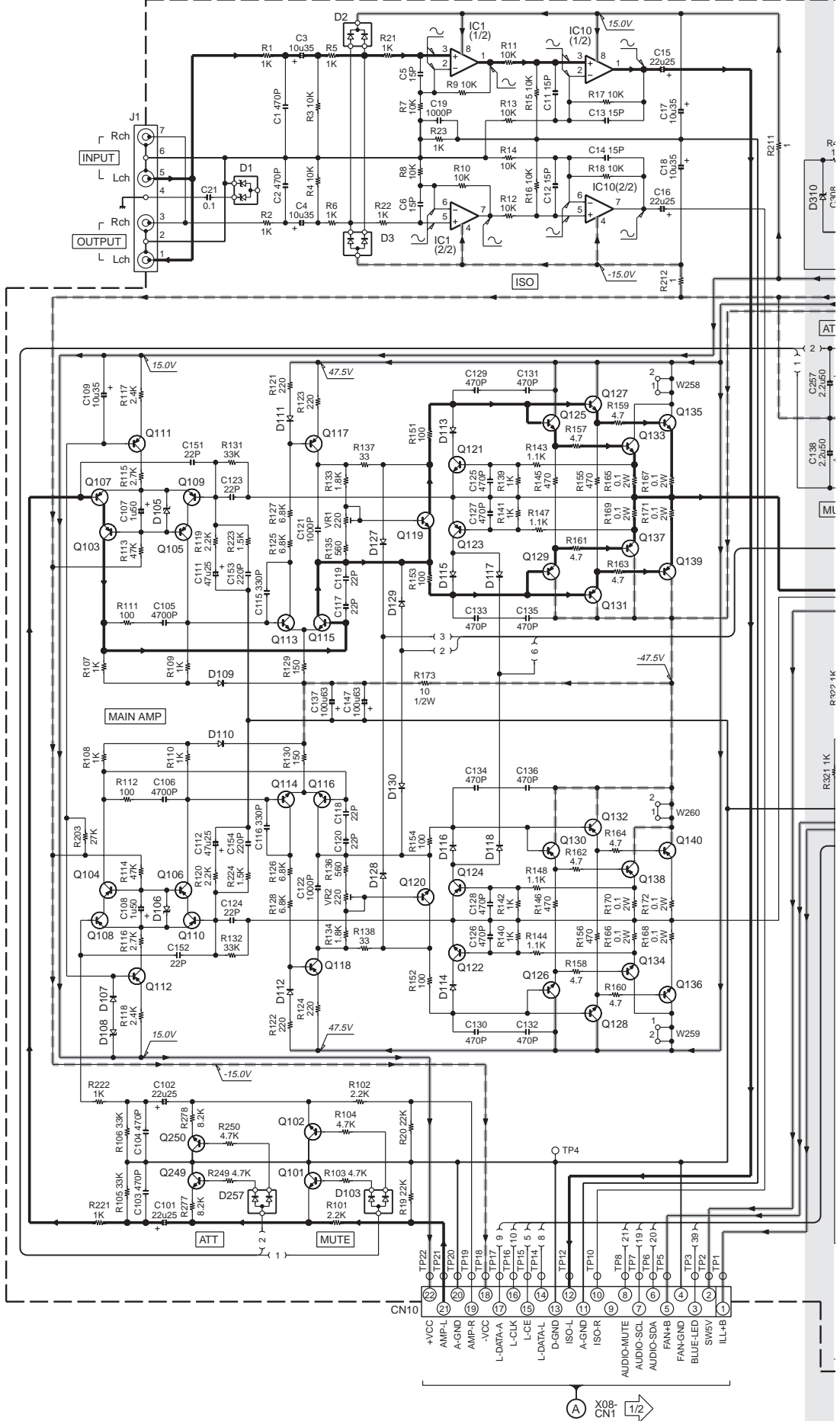

- IC1,9,10 : BA4560F
- IC2 : UPC494GS
- IC3 : P82B96PN
- IC5 : BA10393F
- IC6 : 784224YGC117
- IC7 : PST3436UL-E

- D1,303,306-308,311,313,314 : UMZ6.8N
- D2,81,302,315 : LM1MA142WK-G
- D3,103,257,301 : LM1MA142WA-G
- D51-53 : RM4ZLF-J1NF
- D55 : UDZS4.7B
- D59 : S5566B-Q
- D60 : RD16JS-AZ(B)
- D68 : FCH20A20
- D69 : FRH20A20
- D70 : UDZS6.8B
- D71 : RD15JS-AZ(B)
- D105,106,108 : RD5.1JS-AZ(B2)
- D107,109-118,127-130 : 1SS133
- D131-133,260,304,305,316,341-344 : 1SS355
- D309,317 : DA204U
- D310,351,354 : UDZS5.1B
- D312 : UDZS16B
- D352 : UDZS10B
- D353 : UDZS3.3B

- Q50,68,70,71,97,101,102,144,148,149,249,250,301,304,341-344,357 : 2SC4081
- Q51,52 : 2SC4097
- Q53,54 : 2SA1577
- Q55-60,601,602 : IRFIZ48N
- Q61 : 2SC4883ANF
- Q62 : 2SA1859ANF
- Q63,69,111,112,145,147,302,303,305,306 : 2SA1576A
- Q64 : 2SB1241
- Q65,307,313,346,348,352,353,355 : DTC114EUA
- Q66 : 2SB1239
- Q81 : 2SK246(BL)-F
- Q91,92,310,347,349,351,354 : DTA114EUA
- Q103-110,123,124,142 : 2SA992-A(F,E)
- Q113-116 : 2SC3478AA(L,K)
- Q117,118 : 2SA1376AA(L,K)
- Q119,120 : 2SC3419(Y)
- Q121,122,143,146 : 2SC1845-A(F,E)
- Q125-128 : 2SC2235-F
- Q129-132 : 2SA965-F
- Q133-136 : 2SC3856NF
- Q137-140 : 2SA1492NF
- Q141,263 : DTA124EUA
- Q356,358 : 2SD1863
- Q403,404 : 2SC945AA(Q,P)

_____ SIGNAL LINE
 _____ GND LINE
 _____ +B LINE
 _____ -B LINE

KAC-PS621/X621

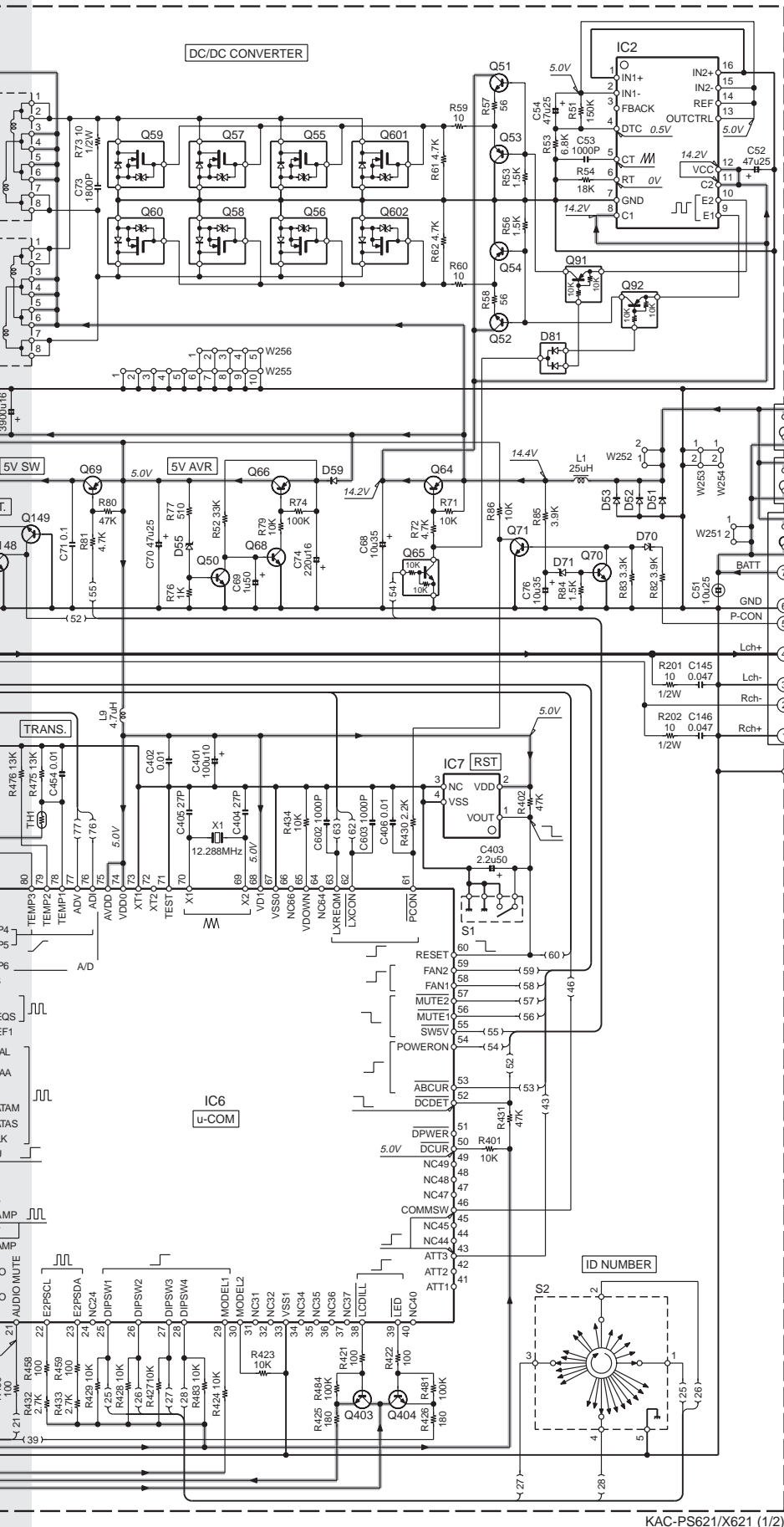

- | | |
|-----------|--------------|
| 2SA965-F | DTA114EUA |
| 2SA992-A | DTA124EUA |
| 2SC1845-A | DTC114EUA |
| 2SC2235-F | |
| | |
| 2SA1576A | NJM4565MD-ZB |
| | |
| 2SC3419 | DA204U |
| | |
| 2SC4081 | 2SK246 |
| | |
| | NJM2058M-ZB |
| | |

CAUTION : For continued safety, replace safety critical components only with manufacturer's recommended parts (refer to parts list).

⚠ Indicates safety critical components. To reduce the risk of electric shock, leakage-current or resistance measurements shall be carried out (exposed parts are acceptably insulated from the supply circuit) before the appliance is returned to the customer.

- DC voltages are as measured with a high impedance voltmeter. Values may vary slightly due to variations between individual instruments or/and units.

KAC-PS621/X621 (1/2)

KAC-PS621/X621

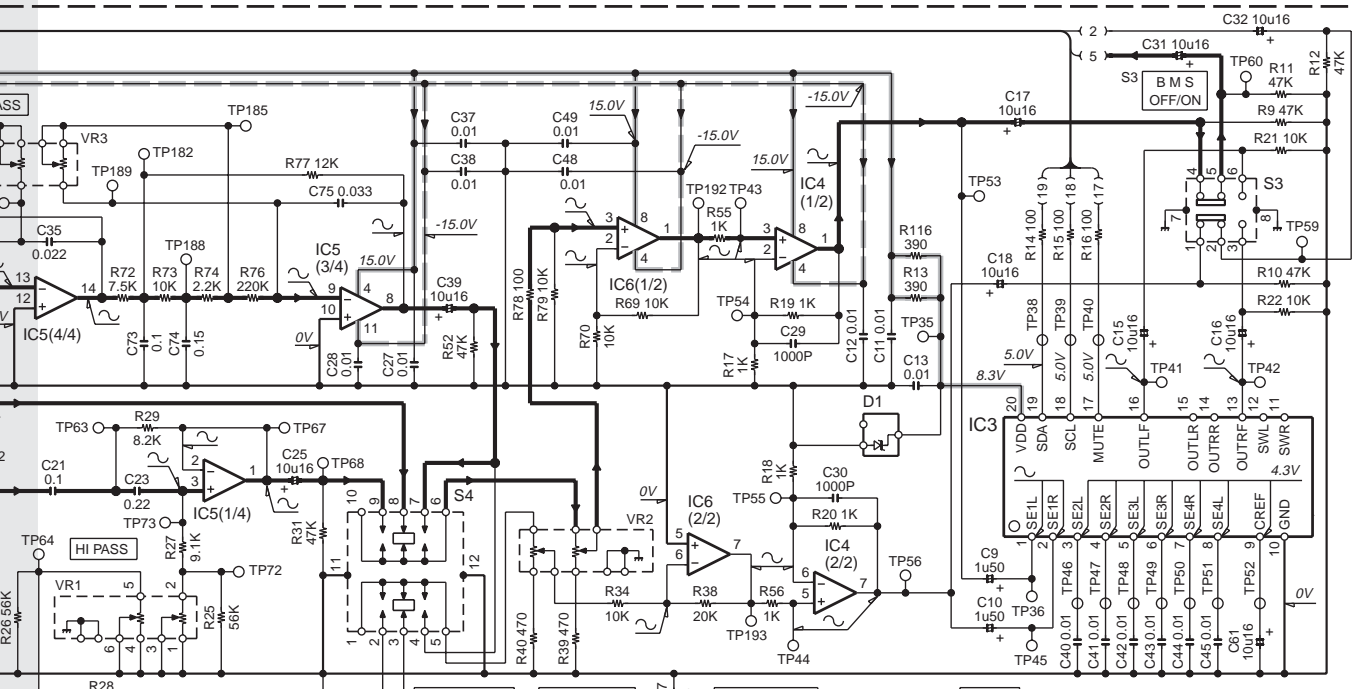

- IC1,5 : NJM2058M-ZB
- IC3 : E-TDA7409DTR
- IC4,6 : NJM4565MD-ZB
- IC7 : LC5853NE-E
- D1 : MA3082-M
- D2 : B30-1694-05

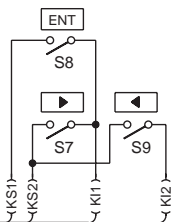
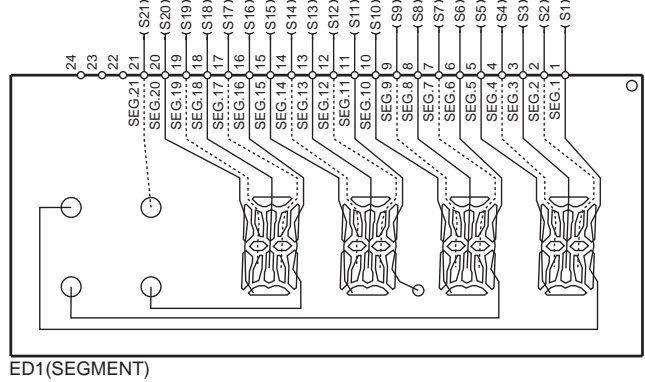
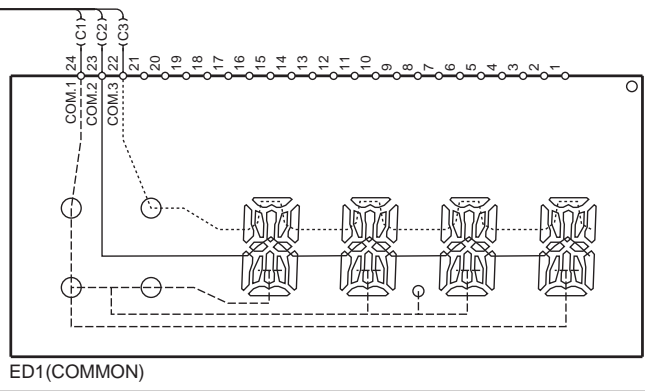
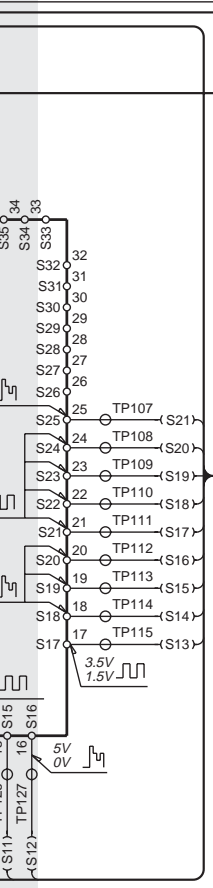
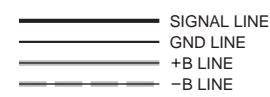

CAUTION : For continued safety, replace safety critical components only with manufacturer's recommended parts (refer to parts list).
 Δ Indicates safety critical components. To reduce the risk of electric shock, leakage-current or resistance measurements shall be carried out (exposed parts are acceptably insulated from the supply circuit) before the appliance is returned to the customer.

- DC voltages are as measured with a high impedance voltmeter. Values may vary slightly due to variations between individual instruments or/and units.

EXPLODED VIEW

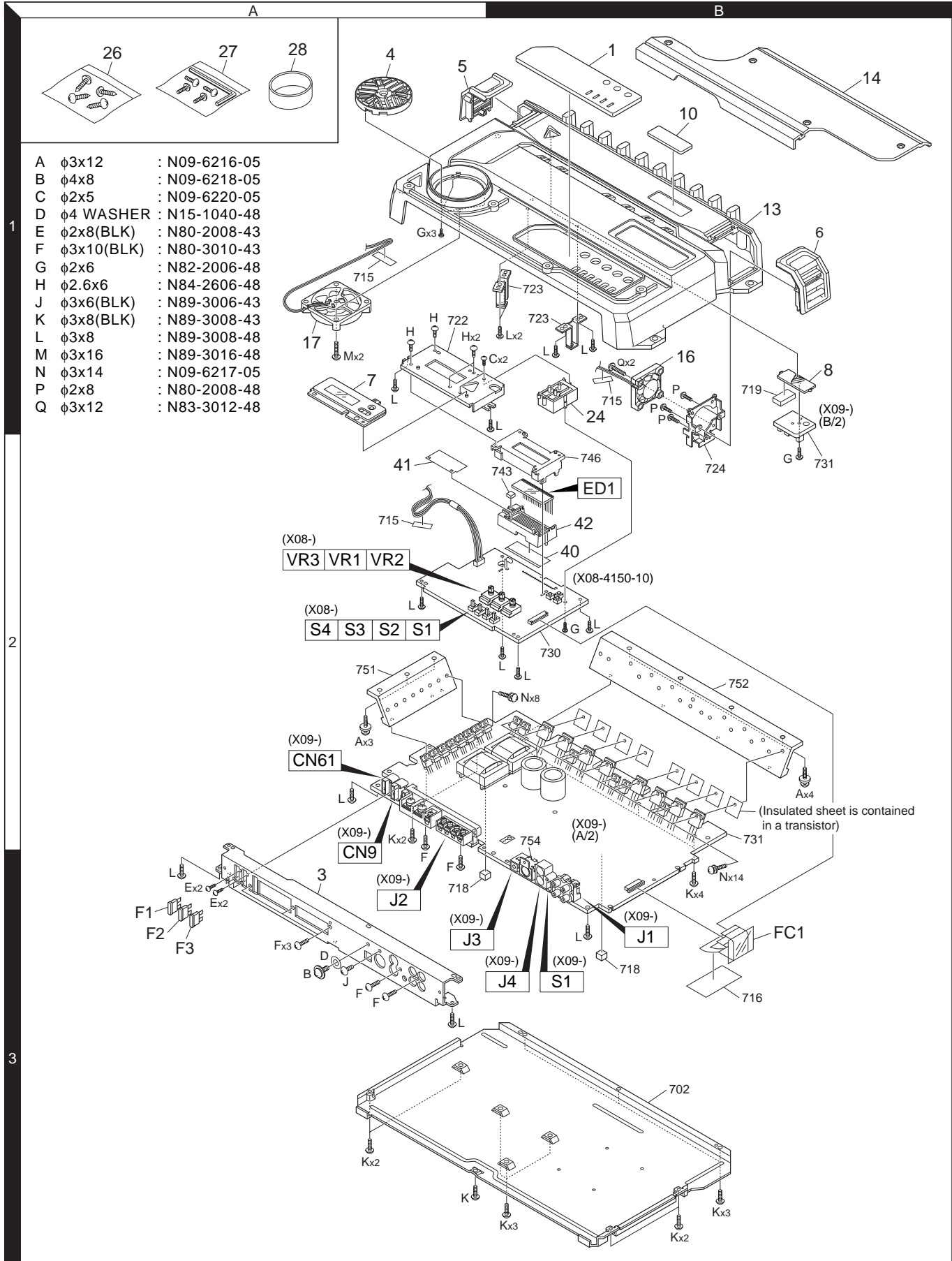

Parts with the exploded numbers larger than 700 are not supplied.

KAC-PS621/X621

PARTS LIST

* New parts

Parts without **Parts No.** are not supplied.

Les articles non mentionnés dans le **Parts No.** ne sont pas fournis.

Teile ohne **Parts No.** werden nicht geliefert.

Ref. No.	A d d	N e w	Parts No.	Description	Desti- nation
KAC-PS621/X621					
1	1B	*	A21-4363-02	DRESSING PANEL	KM1
1	1B	*	A21-4364-02	DRESSING PANEL	E1
3	3A	*	A64-3298-02	PANEL	
4	1A	*	B07-3102-03	ESCUTCHEON	
5	1B	*	B07-3103-02	ESCUTCHEON	
6	1B	*	B07-3104-02	ESCUTCHEON	
7	1A	*	B10-4544-03	FRONT GLASS	
8	1B	*	B19-2257-03	LIGHTING BOARD	
10	1B	*	B43-1521-04	BADGE	KM1
10	1B	*	B43-1522-04	BADGE	E1
-			B46-0100-50	WARRANTY CARD	
-			B46-0648-13	USER CARD	K
-		*	B64-2795-00	INSTRUCT.MANUAL (ENG.FRE.SPA.)	KE1
-		*	B64-2796-00	INST.MANUAL (GER.DUT.ITA.POR.)	E1
-		*	B64-2798-00	INSTRUCTION MANUAL(ENG.T-CHI.)	M1
FC1	3B	*	E39-0642-05	FLAT CABLE	
13	1B	*	F01-1752-01	HEAT SINK	
14	1B	*	F07-1140-12	COVER	KM1
14	1B	*	F07-1141-12	COVER	E1
16	1B	*	F09-1846-05	FAN	
17	1A	*	F09-1885-05	FAN	
△ F1-3	3A		F52-0014-05	FUSE (BLADE TYPE) 25A	
-		*	H10-4894-13	POLYSTYRENE FOAMED FIXTURE	
-		*	H13-2056-04	CARTON BOARD	
-		*	H25-1199-04	PROTECTION BAG	
-		*	H25-1200-04	PROTECTION BAG (250X350X0.03)	
-		*	H54-3136-03	ITEM CARTON CASE	K
-		*	H54-3137-03	ITEM CARTON CASE	E1
-		*	H54-3138-03	ITEM CARTON CASE	M1
24	2B	*	K24-4146-03	KNOB (VR CAP)	
26	1A		N99-1577-15	SCREW SET	
27	1A	*	N99-1752-05	SCREW SET	
A	2A	*	N09-6216-05	TAPTITE SCREW	
B	3A	*	N09-6218-05	TAPTITE SCREW	
C	2B	*	N09-6220-05	MACHINE SCREW	
D	3A	*	N15-1040-48	FLAT WASHER (4)	
E	3A	*	N80-2008-43	PAN HEAD TAPTITE SCREW	
F	3A		N80-3010-43	PAN HEAD TAPTITE SCREW	
G	1A		N82-2006-48	BINDING HEAD TAPTITE SCREW	
H	2A	*	N84-2606-48	PAN HEAD TAPTITE SCREW	
J	3A		N89-3006-43	BINDING HEAD TAPTITE SCREW	
K	3A	*	N89-3008-43	BINDING HEAD TAPTITE SCREW	
L	2A		N89-3008-48	BINDING HEAD TAPTITE SCREW	
M	2A	*	N89-3016-48	BINDING HEAD TAPTITE SCREW	
P	2B	*	N80-2008-48	PAN HEAD TAPTITE SCREW	
Q	2B	*	N83-3012-48	PAN HEAD TAPTITE SCREW	
28	1A		W01-1606-05	ACCESSORY	

Ref. No.	A d d	N e w	Parts No.	Description	Desti- nation
PREAMPLIFIER UNIT (X08-4150-10)					
40	2B	*	B11-1446-04	REFLECTION SHEET	
41	2A	*	B11-1447-04	OPTICAL DIFFUSER	
42	2B	*	B19-2258-12	LIGHTING BOARD	
D2		*	B30-1694-05	LED	
ED1		*	B38-1150-05	LCD DISPLAY ASSY	
C3-6			CK73FB1C224K	CHIP C	0.22UF K
C9,10			CD04AS1H010M	ELECTRO	1UF 50WV
C11-13			CK73GB1H103K	CHIP C	0.010UF K
C15-20			CD04AS1C100M	ELECTRO	10UF 16WV
C21,22			CK73GB1C104K	CHIP C	0.10UF K
C23,24			CK73FB1C224K	CHIP C	0.22UF K
C25,26			CD04AS1C100M	ELECTRO	10UF 16WV
C27,28			CK73GB1H103K	CHIP C	0.010UF K
C29,30			CK73GB1H102K	CHIP C	1000PF K
C31,32			CD04AS1C100M	ELECTRO	10UF 16WV
C33			CK73GB1C104K	CHIP C	0.10UF K
C34			CK73FB1C154K	CHIP C	0.15UF K
C35			CK73GB1E223K	CHIP C	0.022UF K
C37,38			CK73GB1H103K	CHIP C	0.010UF K
C39			CD04AS1C100M	ELECTRO	10UF 16WV
C40-45			CK73GB1H103K	CHIP C	0.010UF K
C48,49			CK73GB1H103K	CHIP C	0.010UF K
C61			CD04AS1C100M	ELECTRO	10UF 16WV
C63-66			CK73FB1C224K	CHIP C	0.22UF K
C67,68			CD04AS1C100M	ELECTRO	10UF 16WV
C73			CK73GB1C104K	CHIP C	0.10UF K
C74			CK73FB1C154K	CHIP C	0.15UF K
C75			CK73GB1E333K	CHIP C	0.033UF K
C101			CK73GB1H821K	CHIP C	820PF K
C102,103			CK73GB1H473K	CHIP C	0.047UF K
C104			CK73GB1H103K	CHIP C	0.010UF K
C105			CD04AS1C100M	ELECTRO	10UF 16WV
C107			CK73GB1H102K	CHIP C	1000PF K
CN1		*	E41-2178-05	FLAT CABLE CONNECTOR	
CN2			E41-0941-05	PIN ASSY	
WH2		*	E39-0655-05	WIRING HARNESS	
R1,2			RK73GB2A473J	CHIP R	47K J 1/10W
R3,4			RK73GB2A134J	CHIP R	130K J 1/10W
R5,6			RK73GB2A223J	CHIP R	22K J 1/10W
R7-12			RK73GB2A473J	CHIP R	47K J 1/10W
R13			RD14BB2C391J	RD	390 J 1/6W
R14-16			RK73GB2A101J	CHIP R	100 J 1/10W
R17-20			RK73GB2A102J	CHIP R	1.0K J 1/10W
R21,22			RK73GB2A103J	CHIP R	10K J 1/10W
R23,24			RK73GB2A473J	CHIP R	47K J 1/10W
R25,26			RK73GB2A563J	CHIP R	56K J 1/10W
R27,28			RK73GB2A912J	CHIP R	9.1K J 1/10W
R29,30			RK73GB2A822J	CHIP R	8.2K J 1/10W
R31-33			RK73GB2A473J	CHIP R	47K J 1/10W
R34			RK73GB2A103J	CHIP R	10K J 1/10W
R38			RK73GB2A203J	CHIP R	20K J 1/10W
R39,40			RK73GB2A471J	CHIP R	470 J 1/10W

E1 : KAC-PS621 K : KAC-X621 M1 : KAC-X621
(E : Europe K : North America M : Other Areas)

△ Indicates safety critical components.

PARTS LIST

* New parts

Parts without **Parts No.** are not supplied.

Les articles non mentionnés dans le **Parts No.** ne sont pas fournis.

Teile ohne **Parts No.** werden nicht geliefert.

PREAMPLIFIER UNIT (X08-4150-10)

Ref. No.	Add	New	Parts No.	Description	Destination	Ref. No.	Add	New	Parts No.	Description	Destination
R41,42			RK73GB2A153J	CHIP R 15K J 1/10W		C55,56		*	CD04BC1C392M	ELECTRO 3900UF 16WV	
R43			RK73GB2A332J	CHIP R 3.3K J 1/10W		C61		*	C90-5592-05	ELECTRO 10UF 35WV	
R44			RK73GB2A222J	CHIP R 2.2K J 1/10W		C62			CK73GB1H103K	CHIP C 0.010UF K	
R45			RK73GB2A153J	CHIP R 15K J 1/10W		C63,64		*	C90-5588-05	ELECTRO 47UF 25WV	
R46			RK73GB2A473J	CHIP R 47K J 1/10W		C65,66			CK73GB1H103K	CHIP C 0.010UF K	
R52			RK73GB2A473J	CHIP R 47K J 1/10W		C67,68		*	C90-5592-05	ELECTRO 10UF 35WV	
R55,56			RK73GB2A102J	CHIP R 1.0K J 1/10W		C69			C90-5601-05	ELECTRO 1UF 50WV	
R63,64			RK73GB2A563J	CHIP R 56K J 1/10W		C70		*	C90-5588-05	ELECTRO 47UF 25WV	
R65,66			RK73GB2A393J	CHIP R 39K J 1/10W		C71			CK73GB1C104K	CHIP C 0.10UF K	
R69,70			RK73GB2A103J	CHIP R 10K J 1/10W		C72			CF92FV1H332J	MF-C 3300PF J	
R72			RK73GB2A752J	CHIP R 7.5K J 1/10W		C73			CF92FV1H182J	MF-C 1800PF J	
R73			RK73GB2A103J	CHIP R 10K J 1/10W		C74		*	C90-5590-05	ELECTRO 220UF 25WV	
R74			RK73GB2A222J	CHIP R 2.2K J 1/10W		C76		*	C90-5592-05	ELECTRO 10UF 35WV	
R76			RK73GB2A224J	CHIP R 220K J 1/10W		C89			CF92FV1H332J	MF-C 3300PF J	
R77			RK73GB2A123J	CHIP R 12K J 1/10W		C90,91		*	C90-5689-05	ELECTRO 4700UF 63WV	
R78			RK73GB2A101J	CHIP R 100 J 1/10W		C101,102		*	C90-5586-05	ELECTRO 22UF 25WV	
R79			RK73GB2A103J	CHIP R 10K J 1/10W		C103,104			CC45FSL1H471J	CERAMIC 470PF J	
R101-104			RK73GB2A471J	CHIP R 470 J 1/10W		C105,106			CK73GB1H472K	CHIP C 4700PF K	
R105			RK73GB2A683J	CHIP R 68K J 1/10W		C107,108			C90-5601-05	ELECTRO 1UF 50WV	
R106			RK73GB2A472J	CHIP R 4.7K J 1/10W		C109		*	C90-5592-05	ELECTRO 10UF 35WV	
R107,108			RK73GB2A471J	CHIP R 470 J 1/10W		C111,112		*	C90-5588-05	ELECTRO 47UF 25WV	
R109-111			RK73GB2A102J	CHIP R 1.0K J 1/10W		C115,116			CC45FSL1H331J	CERAMIC 330PF J	
R112			RK73GB2A104J	CHIP R 100K J 1/10W		C117-120			CC45FSL1H220J	CERAMIC 22PF J	
R114,115			RK73GB2A103J	CHIP R 10K J 1/10W		C121,122			CK45FB1H102K	CERAMIC 1000PF K	
R116			RD14BB2C391J	RD 390 J 1/6W		C123,124			CC45FSL1H220J	CERAMIC 22PF J	
R117			RD14BB2C6R8J	RD 6.8 J 1/6W		C125-128			CK73GB1H471K	CHIP C 470PF K	
VR1			R31-0225-05	VARIABLE RESISTOR		C129-136			CK45FB1H471K	CERAMIC 470PF K	
VR2		*	R31-0238-05	VARIABLE RESISTOR		C137		*	C90-5695-05	ELECTRO 100UF 63WV	
VR3			R31-0225-05	VARIABLE RESISTOR		C138			C90-5602-05	ELECTRO 2.2UF 50WV	
S1-3		*	S62-0873-05	SLIDE SWITCH		C139		*	C90-5570-05	ELECTRO 33UF 10WV	
S4		*	S62-0874-05	SLIDE SWITCH		C140		*	C90-5588-05	ELECTRO 47UF 25WV	
S7-9		*	S70-0922-05	TACT SWITCH		C141			C90-5566-05	ELECTRO 100UF 6.3WV	
D1			MA3082-M	ZENER DIODE		C142			CK73GB1H103K	CHIP C 0.010UF K	
IC1		*	NJM2058M-ZB	ANALOGUE IC		C143			C90-5566-05	ELECTRO 100UF 6.3WV	
IC3		*	E-TDA7409DTR	ANALOGUE IC		C145,146			CF92FV1H473J	MF-C 0.047UF J	
IC4		*	NJM4565MD-ZB	ANALOGUE IC		C147		*	C90-5695-05	ELECTRO 100UF 63WV	
IC5		*	NJM2058M-ZB	ANALOGUE IC		C151,152			CC73GCH1H220J	CHIP C 22PF J	
IC6		*	NJM4565MD-ZB	ANALOGUE IC		C153,154			CC73GCH1H221J	CHIP C 220PF J	
IC7		*	LC75853NE-E	MOS-IC		C251,252			CK73GB1H103K	CHIP C 0.010UF K	
						C257			C90-5602-05	ELECTRO 2.2UF 50WV	
AUDIO UNIT (X09-5770-10)											
D13			B30-1601-05	LED		C260		*	C90-5570-05	ELECTRO 33UF 10WV	
C1,2			CK73GB1H471K	CHIP C 470PF K		C301		*	C90-5557-05	ELECTRO 10UF 25WV	
C3,4		*	C90-5592-05	ELECTRO 10UF 35WV		C302-305			CK73FB1H104K	CHIP C 0.10UF K	
C5,6			CC73GCH1H150J	CHIP C 15PF J		C307			CK73GB1H103K	CHIP C 0.010UF K	
C11-14			CC73GCH1H150J	CHIP C 15PF J		C308		*	C90-5592-05	ELECTRO 10UF 35WV	
C15,16		*	C90-5586-05	ELECTRO 22UF 25WV		C309,310			CK73GB1H103K	CHIP C 0.010UF K	
C17,18		*	C90-5592-05	ELECTRO 10UF 35WV		C311,312			CC73GCH1H101J	CHIP C 100PF J	
C19			CF92FV1H102J	MF-C 1000PF J		C313			CK73GB1H103K	CHIP C 0.010UF K	
C21			CK73FB1H104K	CHIP C 0.10UF K		C314			CK73FB1H104K	CHIP C 0.10UF K	
C51		*	C90-5557-05	ELECTRO 10UF 25WV		C343			CK73GB1H103K	CHIP C 0.010UF K	
C52		*	C90-5588-05	ELECTRO 47UF 25WV		C349,350		*	C90-5592-05	ELECTRO 10UF 35WV	
C53			CK73GB1H102K	CHIP C 1000PF K		C351		*	C90-5588-05	ELECTRO 47UF 25WV	
C54		*	C90-5588-05	ELECTRO 47UF 25WV		C352		*	C90-5592-05	ELECTRO 10UF 35WV	
						C353,354			CK73GB1H103K	CHIP C 0.010UF K	
						C358		*	C90-5592-05	ELECTRO 10UF 35WV	

E1 : KAC-PS621 K : KAC-X621 M1 : KAC-X621
(E : Europe K : North America M : Other Areas)

△ Indicates safety critical components.

PARTS LIST

* New parts

Parts without **Parts No.** are not supplied.

Les articles non mentionnés dans le **Parts No.** ne sont pas fournis.

Teile ohne **Parts No.** werden nicht geliefert.

AUDIO UNIT (X09-5770-10)

Ref. No.	A d d	N e w	Parts No.	Description	Desti- nation
C401			C90-5572-05	ELECTRO 100UF 10WV	
C402			CK73GB1H103K	CHIP C 0.010UF K	
C403			C90-5602-05	ELECTRO 2.2UF 50WV	
C404,405			CC73GCH1H270J	CHIP C 27PF J	
C406			CK73GB1H103K	CHIP C 0.010UF K	
C451-453			CC73GCH1H101J	CHIP C 100PF J	
C454			CK73GB1H103K	CHIP C 0.010UF K	
C456,457			CK73GB1H103K	CHIP C 0.010UF K	
C601		*	CD04BC1C392M	ELECTRO 3900UF 16WV	
C602,603			CK73GB1H102K	CHIP C 1000PF K	
CN1			E41-0928-05	PIN ASSY	
CN2,3			E41-0927-05	PIN ASSY	
CN10		*	E41-2202-05	FLAT CABLE CONNECTOR	
J1		*	E63-0901-05	PIN JACK	
J2			E70-0838-05	SCREW TERMINAL BOARD	
J3		*	E56-0856-05	CYLINDRICAL RECEPTACLE	
J4		*	E56-0853-05	CYLINDRICAL RECEPTACLE	
△ CN9			J13-0602-05	FUSE HOLDER	
△ CN61			J13-0602-05	FUSE HOLDER	
L1		*	L33-1972-05	CHOKE COIL	
L4		*	L19-0754-05	TRANSFORMER FOR CONVERTER	
L5		*	L19-0758-05	TRANSFORMER FOR CONVERTER	
L6		*	L19-0754-05	TRANSFORMER FOR CONVERTER	
L9			L40-4795-68	SMALL FIXED INDUCTOR (4.7UH)	
X1			L77-2844-05	CRYSTAL RESONATOR (12.288MHZ)	
F	3A		N80-3010-43	PAN HEAD TAPTITE SCREW	
K	3A	*	N89-3008-43	BINDING HEAD TAPTITE SCREW	
N	2B	*	N09-6217-05	TAPTITE SCREW	
R1,2			RD14BB2C102J	RD 1.0K J 1/6W	
R3,4			RK73GB2A103J	CHIP R 10K J 1/10W	
R5,6			RK73GB2A102J	CHIP R 1.0K J 1/10W	
R7-10			RK73GB2A103J	CHIP R 10K J 1/10W	
R11-18			RN73GH1J103D	CHIP R 10K D 1/16W	
R19,20			RK73GB2A223J	CHIP R 22K J 1/10W	
R21-23			RK73GB2A102J	CHIP R 1.0K J 1/10W	
R51			RK73GB2A154J	CHIP R 150K J 1/10W	
R52			RK73GB2A333J	CHIP R 33K J 1/10W	
R53			RK73GB2A682J	CHIP R 6.8K J 1/10W	
R54			RK73GB2A183J	CHIP R 18K J 1/10W	
R55,56			RK73GB2A152J	CHIP R 1.5K J 1/10W	
R57,58			RK73GB2A560J	CHIP R 56 J 1/10W	
R59,60			RK73GB2A100J	CHIP R 10 J 1/10W	
R61,62			RK73GB2A472J	CHIP R 4.7K J 1/10W	
R67			RK73GB2A821J	CHIP R 820 J 1/10W	
R69			RK73GB2A153J	CHIP R 15K J 1/10W	
R70			RK73GB2A101J	CHIP R 100 J 1/10W	
R71			RK73GB2A103J	CHIP R 10K J 1/10W	
R72			RK73GB2A472J	CHIP R 4.7K J 1/10W	
R73			RD14DB2H100J	SMALL-RD 10 J 1/2W	
R74			RK73GB2A104J	CHIP R 100K J 1/10W	
R76			RK73GB2A102J	CHIP R 1.0K J 1/10W	
R77			RK73GB2A511J	CHIP R 510 J 1/10W	
R79			RK73GB2A103J	CHIP R 10K J 1/10W	

Ref. No.	A d d	N e w	Parts No.	Description	Desti- nation
R80			RK73GB2A473J	CHIP R 47K J 1/10W	
R81			RK73GB2A472J	CHIP R 4.7K J 1/10W	
R82			RK73GB2A392J	CHIP R 3.9K J 1/10W	
R83			RK73GB2A332J	CHIP R 3.3K J 1/10W	
R84			RK73GB2A152J	CHIP R 1.5K J 1/10W	
R85			RK73GB2A392J	CHIP R 3.9K J 1/10W	
R86			RK73GB2A103J	CHIP R 10K J 1/10W	
R88,89			RD14DB2H100J	SMALL-RD 10 J 1/2W	
R90,91			RD14BB2C563J	RD 56K J 1/6W	
R92			RK73GB2A103J	CHIP R 10K J 1/10W	
R93			RK73GB2A113J	CHIP R 11K J 1/10W	
R101,102			RK73GB2A222J	CHIP R 2.2K J 1/10W	
R103,104			RK73GB2A472J	CHIP R 4.7K J 1/10W	
R105,106			RD14BB2C333J	RD 33K J 1/6W	
R107-110			RK73GB2A102J	CHIP R 1.0K J 1/10W	
R111,112			RK73GB2A101J	CHIP R 100 J 1/10W	
R113,114			RK73GB2A473J	CHIP R 47K J 1/10W	
R115,116			RK73GB2A272J	CHIP R 2.7K J 1/10W	
R117,118			RK73GB2A242J	CHIP R 2.4K J 1/10W	
R119,120			RD14BB2C222J	RD 2.2K J 1/6W	
R121-124			RD14BB2C221J	RD 220 J 1/6W	
R125-128			RD14BB2C682J	RD 6.8K J 1/6W	
R129,130			RD14BB2C151J	RD 150 J 1/6W	
R131,132			RD14BB2C333J	RD 33K J 1/6W	
R133,134			RD14BB2C182J	RD 1.8K J 1/6W	
R135,136			RD14BB2C561J	RD 560 J 1/6W	
R137,138			RD14BB2C330J	RD 33 J 1/6W	
R139-142			RK73GB2A102J	CHIP R 1.0K J 1/10W	
R143,144			RK73GB2A112J	CHIP R 1.1K J 1/10W	
R145,146			RD14NB2E471J	RD 470 J 1/4W	
R147,148			RK73GB2A112J	CHIP R 1.1K J 1/10W	
R151-154			RD14NB2E101J	RD 100 J 1/4W	
R155,156			RD14NB2E471J	RD 470 J 1/4W	
R157-164			RD14NB2E4R7J	RD 4.7 J 1/4W	
R165-172			R92-0205-05	METAL-PLATE 0.1 K 2W	
R173			RD14DB2H100J	SMALL-RD 10 J 1/2W	
R174			RK73GB2A333J	CHIP R 33K J 1/10W	
R175			RK73GB2A153J	CHIP R 15K J 1/10W	
R176			RK73GB2A331J	CHIP R 330 J 1/10W	
R177			RK73GB2A223J	CHIP R 22K J 1/10W	
R178,179			RK73GB2A470J	CHIP R 47 J 1/10W	
R180,181			RK73GB2A682J	CHIP R 6.8K J 1/10W	
R182,183			RK73GB2A103J	CHIP R 10K J 1/10W	
R184-186			RK73GB2A473J	CHIP R 47K J 1/10W	
R187,188			RK73GB2A103J	CHIP R 10K J 1/10W	
R189			RK73GB2A102J	CHIP R 1.0K J 1/10W	
R190			RK73GB2A103J	CHIP R 10K J 1/10W	
R191			RK73GB2A562J	CHIP R 5.6K J 1/10W	
R192			RK73GB2A153J	CHIP R 15K J 1/10W	
R193			RK73GB2A223J	CHIP R 22K J 1/10W	
R194			RK73GB2A822J	CHIP R 8.2K J 1/10W	
R195			RK73GB2A103J	CHIP R 10K J 1/10W	
R196			RK73GB2A104J	CHIP R 100K J 1/10W	
R197,198			RK73GB2A473J	CHIP R 47K J 1/10W	
R199			RK73GB2A562J	CHIP R 5.6K J 1/10W	

E1 : KAC-PS621 K : KAC-X621 M1 : KAC-X621
(E : Europe K : North America M : Other Areas)

△ Indicates safety critical components.

PARTS LIST

* New parts

Parts without **Parts No.** are not supplied.

Les articles non mentionnés dans le **Parts No.** ne sont pas fournis.

Teile ohne **Parts No.** werden nicht geliefert.

AUDIO UNIT (X09-5770-10)

Ref. No.	Add	New	Parts No.	Description	Destination	Ref. No.	Add	New	Parts No.	Description	Destination
R200			RK73GB2A332J	CHIP R 3.3K J 1/10W		R432,433			RK73GB2A272J	CHIP R 2.7K J 1/10W	
R201,202			RD14DB2H100J	SMALL-RD 10 J 1/2W		R434			RK73GB2A103J	CHIP R 10K J 1/10W	
R203			RK73GB2A273J	CHIP R 27K J 1/10W		R438			RK73GB2A153J	CHIP R 15K J 1/10W	
R211,212			RK73GB2A1R0J	CHIP R 1.0 J 1/10W		R439			RK73GB2A181J	CHIP R 180 J 1/10W	
R221,222			RK73GB2A102J	CHIP R 1.0K J 1/10W		R440			RK73GB2A103J	CHIP R 10K J 1/10W	
R223,224			RK73GB2A152J	CHIP R 1.5K J 1/10W		R441			RK73GB2A102J	CHIP R 1.0K J 1/10W	
R241			RK73GB2A512J	CHIP R 5.1K J 1/10W		R442			RK73GB2A182J	CHIP R 1.8K J 1/10W	
R249,250			RK73GB2A472J	CHIP R 4.7K J 1/10W		R443,444			RK73GB2A272J	CHIP R 2.7K J 1/10W	
R263			RK73GB2A333J	CHIP R 33K J 1/10W		R450-453			RK73GB2A102J	CHIP R 1.0K J 1/10W	
R266			RK73GB2A153J	CHIP R 15K J 1/10W		R454,455			RK73GB2A101J	CHIP R 100 J 1/10W	
R269			RK73GB2A331J	CHIP R 330 J 1/10W		R458-460			RK73GB2A101J	CHIP R 100 J 1/10W	
R272			RK73GB2A223J	CHIP R 22K J 1/10W		R475,476			RK73GB2A133J	CHIP R 13K J 1/10W	
R277,278			RK73GB2A822J	CHIP R 8.2K J 1/10W		R477,478			RK73GB2A113J	CHIP R 11K J 1/10W	
R301,302			RD14BB2C271J	RD 270 J 1/6W		R479,480			RK73GB2A103J	CHIP R 10K J 1/10W	
R303,304			RK73GB2A432J	CHIP R 4.3K J 1/10W		R481,482			RK73GB2A104J	CHIP R 100K J 1/10W	
R306,307			RN73GH1J103D	CHIP R 10K D 1/16W		R483			RK73GB2A103J	CHIP R 10K J 1/10W	
R308,309			RK73GB2A470J	CHIP R 47 J 1/10W		VR1,2			R12-0092-05	TRIMMING POT. (220)	
R310			RK73GB2A682J	CHIP R 6.8K J 1/10W		W301-319			R92-1252-05	CHIP R 0 OHM J 1/16W	
R311			RK73GB2A113J	CHIP R 11K J 1/10W		W321-324			R92-1252-05	CHIP R 0 OHM J 1/16W	
R312,313			RK73GB2A152J	CHIP R 1.5K J 1/10W		W327			R92-1252-05	CHIP R 0 OHM J 1/16W	
R314			RK73GB2A113J	CHIP R 11K J 1/10W		W329-332			R92-1252-05	CHIP R 0 OHM J 1/16W	
R315			RK73GB2A682J	CHIP R 6.8K J 1/10W		W334-366			R92-1252-05	CHIP R 0 OHM J 1/16W	
R316,317			RK73GB2A152J	CHIP R 1.5K J 1/10W		W368-377			R92-1252-05	CHIP R 0 OHM J 1/16W	
R318			RD14BB2C153J	RD 15K J 1/6W		W379-396			R92-1252-05	CHIP R 0 OHM J 1/16W	
R319			RD14BB2C104J	RD 100K J 1/6W		W398-405			R92-1252-05	CHIP R 0 OHM J 1/16W	
R320			RD14BB2C153J	RD 15K J 1/6W		S1			S68-0806-05	PUSH SWITCH	
R321,322			RD14BB2C102J	RD 1.0K J 1/6W		S2	*		S79-0843-05	DIP SWITCHES	
R323			RK73GB2A392J	CHIP R 3.9K J 1/10W		D1			UMZ6.8N	ZENER DIODE	
R324			RK73GB2A272J	CHIP R 2.7K J 1/10W		D2	*		LM1MA142WK-G	DIODE	
R325,326			RK73GB2A105J	CHIP R 1.0M J 1/10W		D3	*		LM1MA142WA-G	DIODE	
R328,329			RK73GB2A472J	CHIP R 4.7K J 1/10W		D51-53	*		RM4ZLF-J1NF	DIODE	
R330,331			RK73GB2A470J	CHIP R 47 J 1/10W		D55			UDZS4.7B	ZENER DIODE	
R332			RK73GB2A102J	CHIP R 1.0K J 1/10W		D59	*		S5566B-Q	DIODE	
R333			RK73GB2A472J	CHIP R 4.7K J 1/10W		D60	*		RD16JS-AZ(B)	ZENER DIODE	
R334,335			RD14BB2C470J	RD 47 J 1/6W		D68	*		FCH20A20	DIODE	
R336			RK73GB2A104J	CHIP R 100K J 1/10W		D69	*		FRH20A20	DIODE	
R337-339			RK73GB2A103J	CHIP R 10K J 1/10W		D70			UDZS6.8B	ZENER DIODE	
R341,342			RK73GB2A472J	CHIP R 4.7K J 1/10W		D71			RD15JS-AZ(B)	ZENER DIODE	
R344			RK73GB2A473J	CHIP R 47K J 1/10W		D81	*		LM1MA142WK-G	DIODE	
R345			RD14BB2C473J	RD 47K J 1/6W		D103			LM1MA142WA-G	DIODE	
R347			RK73GB2A104J	CHIP R 100K J 1/10W		D105,106			RD5.1JS-AZ(B2)	ZENER DIODE	
R348,349			RK73GB2A182J	CHIP R 1.8K J 1/10W		D107			1SS133	DIODE	
R350,351			RK73GB2A103J	CHIP R 10K J 1/10W		D108			RD5.1JS-AZ(B2)	ZENER DIODE	
R352			RK73GB2A302J	CHIP R 3.0K J 1/10W		D109-118			1SS133	DIODE	
R353			RK73GB2A152J	CHIP R 1.5K J 1/10W		D127-130			1SS133	DIODE	
R354-357			RK73GB2A100J	CHIP R 10 J 1/10W		D131-133			1SS355	DIODE	
R360			RK73GB2A103J	CHIP R 10K J 1/10W		D251			1SS133	DIODE	
R401			RK73GB2A103J	CHIP R 10K J 1/10W		D257			LM1MA142WA-G	DIODE	
R402			RK73GB2A473J	CHIP R 47K J 1/10W		D260			1SS355	DIODE	
R421,422			RK73GB2A101J	CHIP R 100 J 1/10W		D301			LM1MA142WA-G	DIODE	
R423,424			RK73GB2A103J	CHIP R 10K J 1/10W		D302	*		LM1MA142WK-G	DIODE	
R425,426			RK73GB2A181J	CHIP R 180 J 1/10W		D303			UMZ6.8N	ZENER DIODE	
R427-429			RK73GB2A103J	CHIP R 10K J 1/10W		D304,305			1SS355	DIODE	
R430			RK73GB2A222J	CHIP R 2.2K J 1/10W		D306-308			UMZ6.8N	ZENER DIODE	
R431			RK73GB2A473J	CHIP R 47K J 1/10W							

E1 : KAC-PS621 K : KAC-X621 M1 : KAC-X621
(E : Europe K : North America M : Other Areas)

△ Indicates safety critical components.

PARTS LIST

* New parts

Parts without **Parts No.** are not supplied.

Les articles non mentionnés dans le **Parts No.** ne sont pas fournis.

Teile ohne **Parts No.** werden nicht geliefert.

AUDIO UNIT (X09-5770-10)

Ref. No.	A d d	N e w	Parts No.	Description	Desti- nation
D309			DA204U	DIODE	
D310			UDZS5.1B	ZENER DIODE	
D311			UMZ6.8N	ZENER DIODE	
D312		*	UDZS16B	ZENER DIODE	
D313,314			UMZ6.8N	ZENER DIODE	
D315		*	LM1MA142WK-G	DIODE	
D316			1SS355	DIODE	
D317			DA204U	DIODE	
D341-344			1SS355	DIODE	
D351			UDZS5.1B	ZENER DIODE	
D352			UDZS10B	ZENER DIODE	
D353		*	UDZS3.3B	ZENER DIODE	
D354			UDZS5.1B	ZENER DIODE	
IC1			BA4560F	IC	
IC2			UPC494GS	ANALOGUE IC	
IC3		*	P82B96PN	ANALOGUE IC	
IC5			BA10393F	ANALOGUE IC	
IC6		*	784224YGC117	MICROCONTROLLER IC	
IC7			PST3436UL-E	MOS-IC	
IC9,10			BA4560F	IC	
Q50			2SC4081	TRANSISTOR	
Q51,52			2SC4097	TRANSISTOR	
Q53,54			2SA1577	TRANSISTOR	
Q55-60			IRFIZ48N	FET	
Q61		*	2SC4883ANF	TRANSISTOR	
Q62		*	2SA1859ANF	TRANSISTOR	
Q63			2SA1576A	TRANSISTOR	
Q64			2SB1241	TRANSISTOR	
Q65			DTC114EUA	DIGITAL TRANSISTOR	
Q66			2SB1238	TRANSISTOR	
Q68			2SC4081	TRANSISTOR	
Q69			2SA1576A	TRANSISTOR	
Q70,71			2SC4081	TRANSISTOR	
Q81		*	2SK246(BL)-F	FET	
Q91,92			DTA114EUA	DIGITAL TRANSISTOR	
Q97			2SC4081	TRANSISTOR	
Q101,102			2SC4081	TRANSISTOR	
Q103-110		*	2SA992-A(F,E)	TRANSISTOR	
Q111,112			2SA1576A	TRANSISTOR	
Q113-116		*	2SC3478AA(L,K)	TRANSISTOR	
Q117,118		*	2SA1376AA(L,K)	TRANSISTOR	
Q119,120			2SC3419(Y)	TRANSISTOR	
Q121,122		*	2SC1845-A(F,E)	TRANSISTOR	
Q123,124		*	2SA992-A(F,E)	TRANSISTOR	
Q125-128		*	2SC2235-F	TRANSISTOR	
Q129-132		*	2SA965-F	TRANSISTOR	
Q133-136		*	2SC3856NF	TRANSISTOR	
Q137-140		*	2SA1492NF	TRANSISTOR	
Q141			DTA124EUA	DIGITAL TRANSISTOR	
Q142		*	2SA992-A(F,E)	TRANSISTOR	
Q143		*	2SC1845-A(F,E)	TRANSISTOR	
Q144			2SC4081	TRANSISTOR	
Q145			2SA1576A	TRANSISTOR	
Q146		*	2SC1845-A(F,E)	TRANSISTOR	
Q147			2SA1576A	TRANSISTOR	

Ref. No.	A d d	N e w	Parts No.	Description	Desti- nation
Q148,149			2SC4081	TRANSISTOR	
Q249,250			2SC4081	TRANSISTOR	
Q263			DTA124EUA	DIGITAL TRANSISTOR	
Q301			2SC4081	TRANSISTOR	
Q302,303			2SA1576A	TRANSISTOR	
Q304			2SC4081	TRANSISTOR	
Q305,306			2SA1576A	TRANSISTOR	
Q307			DTC114EUA	DIGITAL TRANSISTOR	
Q310			DTA114EUA	DIGITAL TRANSISTOR	
Q313			DTC114EUA	DIGITAL TRANSISTOR	
Q341-344			2SC4081	TRANSISTOR	
Q346			DTC114EUA	DIGITAL TRANSISTOR	
Q347			DTA114EUA	DIGITAL TRANSISTOR	
Q348			DTC114EUA	DIGITAL TRANSISTOR	
Q349			DTA114EUA	DIGITAL TRANSISTOR	
Q351			DTA114EUA	DIGITAL TRANSISTOR	
Q352,353			DTC114EUA	DIGITAL TRANSISTOR	
Q354			DTA114EUA	DIGITAL TRANSISTOR	
Q355			DTC114EUA	DIGITAL TRANSISTOR	
Q356			2SD1863	TRANSISTOR	
Q357			2SC4081	TRANSISTOR	
Q358			2SD1863	TRANSISTOR	
Q403,404		*	2SC945AA(Q,P)	TRANSISTOR	
Q601,602			IRFIZ48N	FET	
TH1		*	NT732ATTD103J	THERMISTOR	
TH3,4		*	NT732ATTD103J	THERMISTOR	

E1 : KAC-PS621 K : KAC-X621 M1 : KAC-X621
(E : Europe K : North America M : Other Areas)

△ Indicates safety critical components.

PARTS LIST

CAPACITORS

CC 45 TH 1H 220 J
 1 2 3 4 5 6

- 1 = Type ... ceramic, electrolytic, etc.
- 2 = Shape ... round, square, etc.
- 3 = Temp. coefficient
- 4 = Voltage rating
- 5 = Value
- 6 = Tolerance

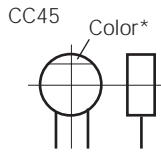

• Capacitor value

- 010 = 1pF
- 100 = 10pF
- 101 = 100pF
- 102 = 1000pF = 0.001μF
- 103 = 0.01μF

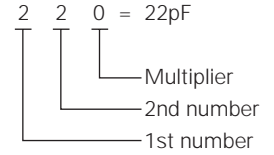

• Temperature coefficient

1st Word	C	L	P	R	S	T	U
Color*	Black	Red	Orange	Yellow	Green	Blue	Violet
ppm/°C	0	-80	-150	-220	-330	-470	-750

2nd Word	G	H	J	K	L
ppm/°C	±30	±60	±120	±250	±500

Example : CC45TH = -470±60ppm/°C

• Tolerance (More than 10pF)

Code	C	D	G	J	K	M	X	Z	P	No code
(%)	±0.25	±0.5	±2	±5	±10	±20	+40 -20	+80 -20	+100 -0	More than 10μF : -10~+50 Less than 4.7μF : -10~+75

(Less than 10pF)

Code	B	C	D	F	G
(pF)	±0.1	±0.25	±0.5	±1	±2

• Voltage rating

2nd word \ 1st word	A	B	C	D	E	F	G	H	J	K	V
0	1.0	1.25	1.6	2.0	2.5	3.15	4.0	5.0	6.3	8.0	-
1	10	12.5	16	20	25	31.5	40	50	63	80	35
2	100	125	160	200	250	315	400	500	630	800	-
3	1000	1250	1600	2000	2500	2150	4000	5000	6300	8000	-

CHIP CAPACITORS

(EX) CC 73 F SL 1H 000 J
 1 2 3 4 5 6 7
 (Chip) (CH, RH, UJ, SL)

(EX) CK 73 F F 1H 000 Z
 1 2 3 4 5 6 7
 (Chip) (B, F)

Refer to the table above.

- 1 = Type
- 2 = Shape
- 3 = Dimension
- 4 = Temp. coefficient
- 5 = Voltage rating
- 6 = Value
- 7 = Tolerance

• Dimension

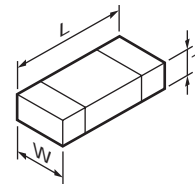

Chip capacitor

Code	L	W	T
Empty	5.6±0.5	5.0±0.5	Less than 2.0
A	4.5±0.5	3.2±0.4	Less than 2.0
B	4.5±0.5	2.0±0.3	Less than 2.0
C	4.5±0.5	1.25±0.2	Less than 1.25
D	3.2±0.4	2.5±0.3	Less than 1.5
E	3.2±0.2	1.6±0.2	Less than 1.25
F	2.0±0.3	1.25±0.2	Less than 1.25
G	1.6±0.2	0.8±0.2	Less than 1.0
H	1.0±0.05	0.5±0.05	0.5±0.05

Chip resistor

Code	L	W	T
E	3.2±0.2	1.6±0.2	1.0
F	2.0±0.3	1.25±0.2	1.0
G	1.6±0.2	0.8±0.2	0.5±0.1
H	1.0±0.05	0.5±0.05	0.35±0.05

RESISTORS

• Chip resistor (Carbon)

(EX) RD 73 E B 2B 000 J
 1 2 3 4 5 6 7
 (Chip) (B, F)

• Carbon resistor (Normal type)

(EX) RD 14 B B 2C 000 J
 1 2 3 4 5 6 7
 (Chip) (B, F)

- 1 = Type ... ceramic, electrolytic, etc.
- 2 = Shape ... round, square, etc.
- 3 = Dimension
- 4 = Temp. coefficient
- 5 = Voltage rating
- 6 = Value
- 7 = Tolerance

• Rating wattage

Code	Wattage	Code	Wattage	Code	Wattage
1J	1/16W	2C	1/6W	3A	1W
2A	1/10W	2E	1/4W	3D	2W
2B	1/8W	2H	1/2W		

KAC-PS621/X621

SPECIFICATIONS

KAC-PS621

AUDIO SECTION

Rated Power Output (4Ω, 20Hz-20kHz, 12V) ...	100W x 2 (0.05% THD)
(2Ω, 1kHz, 12V)	200W x 2 (0.5% THD)
Bridged Power (4Ω, 1kHz, 12V)	400W x 1 (0.5% THD)
Rated Power Output (4Ω, 20Hz-20kHz, 14.4V) ...	150W x 2 (0.05% THD)
(4Ω, DIN45324, 14.4V)	150W x 2
(2Ω, 1kHz, 14.4V)	300W x 2 (0.5% THD)
Bridged Power (4Ω, 1kHz, 14.4V)	600W x 1 (0.5% THD)
MAX Power Output	1200W
Low-Pass Filter	50Hz-200Hz (24dB/oct)
High-Pass Filter	50Hz-200Hz (12dB/oct)
Infrasonic Filter	15Hz (24dB/oct)
Frequency Response	5Hz-70kHz (+0, -3dB)
S/N Ratio	105dB
Sensitivity (Max)	0.2V (Rated Output)
Sensitivity (Min)	5V (Rated Output)
Input Impedance	10kΩ

AMP CONTROL SECTION (EQ)

Bass Frequency Control	60Hz, 80Hz, 100Hz, 200Hz
Bass Level Control	-15dB to +15dB
Bass Q Factor Control	1.00, 1.25, 1.50, 2.00
Treble Frequency Control	10kHz, 12kHz, 15kHz, 17kHz
Treble Level Control	-15dB to +15dB

GENERAL

Operating Voltage (11-16V allowable)	14.4V
Current Consumption (1kHz, 10% THD) at 4Ω	40A
Size (with out dress plate) (W x H x D)	
.....	446 x 61 x 259.5 (mm), 17-3/5 x 2-2/5 x 10-1/5 (inch)
Installation Size (foot point) (W x H x D)	
.....	446 x 61 x 265 (mm), 17-3/5 x 2-2/5 x 10-2/5 (inch)
Weight	4.42kg (9.74 lbs)

Installation

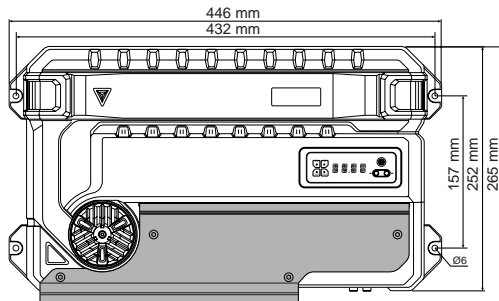

KENWOOD CORPORATION

2967-3, Ishikawa-machi, Hachioji-shi, Tokyo, 192-8525 Japan

KENWOOD USA CORPORATION

P.O. Box 22745, 2201 East Dominguez Street, Long Beach, CA 90801-5745, U.S.A.

KENWOOD ELECTRONICS CANADA INC.

6070 Kestrel Road, Mississauga, Ontario, Canada L5T 1S8

KENWOOD ELECTRONICS LATIN AMERICA S.A.

P.O. Box 55-2791 Paitilla, Plaza Credicorp Bank Panama,
Piso 9, Oficina 901, Calle 50, Panama, Rep. de Panama

KENWOOD ELECTRONICS BRASIL LTDA.

Alameda Ministro Rocha Azevedo No. 456,
Edifício Jaú, 10o Andar, Cerqueira César, Cep 01400-001,
São Paulo-SP-Brasil

KENWOOD ELECTRONICS UK LIMITED

Kenwood House, Dwight Road, Watford, Herts, WD18 9EB, United Kingdom

KENWOOD ELECTRONICS DEUTSCHLAND GMBH

Rembrücker-Str. 15, 63150 Heusenstamm, Germany

KENWOOD ELECTRONICS FRANCE S.A.

13, Boulevard Ney, 75018 Paris, France

KENWOOD ELECTRONICS BELGIUM N.V.

Leuvensesteenweg 248 J, 1800 Vilvoorde, Belgium

KAC-X621

AUDIO SECTION

RMS Power Output (4Ω/2ch, 14.4V)	179W (1.0% THD+N)
(2Ω/2ch, 14.4V)	305W (1.0% THD+N)
RMS Bridged Output (4Ω, 14.4V)	612W (1.0% THD+N)
Dynamic Power	191W
Output Regulation	Under 0.3dB (4Ω)
Signal to Noise Ratio	83dB (w/4Ω)
Signal to Noise Ratio (Bypass)	83dB (w/4Ω)
Rated Power Output (4Ω, 20Hz-20kHz, 12V) ...	100W x 2 (0.05% THD)
(2Ω, 1kHz, 12V)	200W x 2 (0.5% THD)
Bridged Power (4Ω, 1kHz, 12V)	400W x 1 (0.5% THD)
Rated Power Output (4Ω, 20Hz-20kHz, 14.4V) ...	150W x 2 (0.05% THD)
(4Ω, DIN45324, 14.4V)	150W x 2
(2Ω, 1kHz, 14.4V)	300W x 2 (0.5% THD)
Bridged Power (4Ω, 1kHz, 14.4V)	600W x 1 (0.5% THD)
MAX Power Output	1200W
Low-Pass Filter	50Hz-200Hz (24dB/oct)
High-Pass Filter	50Hz-200Hz (12dB/oct)
Infrasonic Filter	15Hz (24dB/oct)
Frequency Response	5Hz-70kHz (+0, -3dB)
Sensitivity (Max)	0.2V (Rated Output)
Sensitivity (Min)	5V (Rated Output)
Input Impedance	10kΩ

AMP CONTROL SECTION (EQ)

Bass Frequency Control	60Hz, 80Hz, 100Hz, 200Hz
Bass Level Control	-15dB to +15dB
Bass Q Factor Control	1.00, 1.25, 1.50, 2.00
Treble Frequency Control	10kHz, 12kHz, 15kHz, 17kHz
Treble Level Control	-15dB to +15dB

GENERAL

Operating Voltage (11-16V allowable)	14.4V
Current Consumption (1kHz, 10% THD) at 4Ω	40A
Size (with out dress plate) (W x H x D)	
.....	446 x 61 x 259.5 (mm), 17-3/5 x 2-2/5 x 10-1/5 (inch)
Installation Size (foot point) (W x H x D)	
.....	446 x 61 x 265 (mm), 17-3/5 x 2-2/5 x 10-2/5 (inch)
Weight	4.42kg (9.74 lbs)

KENWOOD follows a policy of continuous advancements in development. For this reason specifications may be changed without notice.

KENWOOD ELECTRONICS ITALIA S.p.A.

Via G. Sirtori 7/9, 20129 Milano, Italy

KENWOOD IBÉRICA S.A.

Bolivia, 239-08020 Barcelona, Spain

KENWOOD ELECTRONICS AUSTRALIA PTY. LTD. (A.C.N. 001 499 074)

16 Giffnock Avenue, Centrecourt Estate, North Ryde,
N.S.W. 2113, Australia

KENWOOD ELECTRONICS (HONG KONG) LTD.

Unit 3712-3724, Level 37, Tower 1, Metroplaza, 223 Hing Fong Road, Kwai Fong, N.T.,
Hong Kong

KENWOOD ELECTRONICS GULF FZE

P.O. Box 61318, Jebel Ali, Dubai, U.A.E.

KENWOOD ELECTRONICS (THAILAND) CO., LTD.

956 Udom Vidhya Building (Olympia) Rama IV Road, Silom, Bangrak, Bangkok 10500 Thailand

KENWOOD ELECTRONICS SINGAPORE PTE. LTD.

1 Genting Lane, #07-00, Kenwood Building, Singapore, 349544

KENWOOD ELECTRONICS (MALAYSIA) SDN BHD

#4.01 Level 4, Wisma Academy Lot 4A, Jalan 19/1, 46300 Petaling Jaya, Selangor Darul Ehsan,
Malaysia